

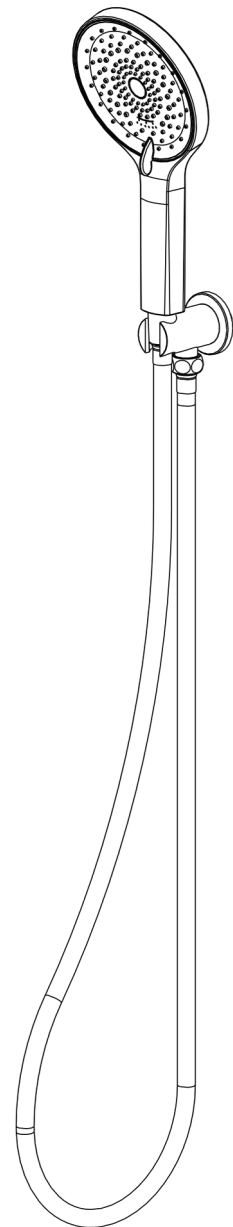

Rain Shower System

Instruction Manual

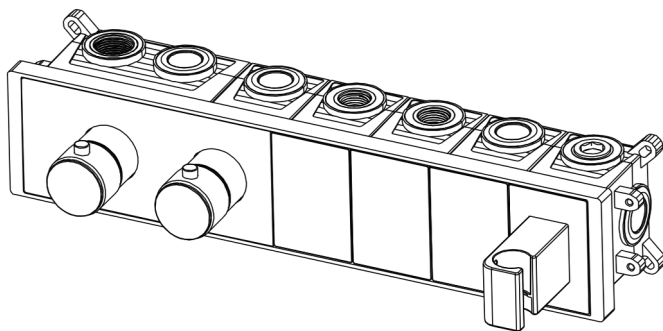
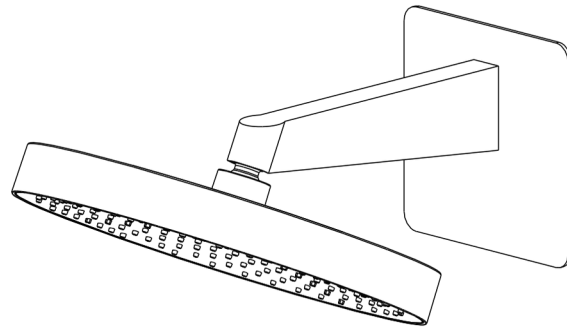

Before Installation:



Thank you for choosing our Rain Shower System. Hope that you'll enjoy a comfortable smooth bathing experience with this product. Before installation, please read this installation manual carefully and keep it properly in case you need it . This manual is about the installation and use of this Rain Shower System.

Technique Requirement

1. Proper Water pressure should be between 0.1Mpa-1.0Mpa, If water supply pressure exceeds 1.0 Mpa, a pressure reducing valve must be fitted.
2. Clean the impurity and sludge in the hose before assembling to avoid leaking and blockage
3. This shower system needs to be installed inside the wall. Please read this manual carefully to confirm the dimensions of products and keep the proper position on the wall.
4. The intake/outlet pipes need to be wrapped with Teflon tape. Use a Teflon tape to wrap a few turns in the clockwise direction on the thread of the pipes. (This is very important. The direction of the Teflon tape must be tangled clockwise. If not, it will leak.)
5. Turn off the water supply before installation

Installation Tools To Be Needed

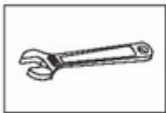

Adjustable wrench



Hexagon wrench
(included)

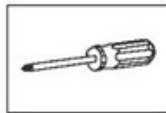

Philips Screwdriver



Pipe Tape

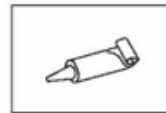

Glue

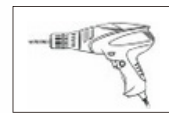

Electric drill

Inventory Accessories

Please check carefully to make sure all the accessories are included in the package, if there is something missing, please contact the seller immediately.

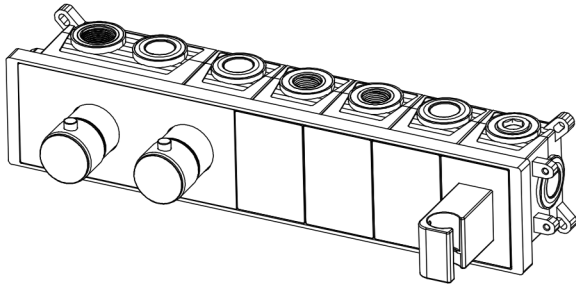

Instructions for concealed installation of shower body

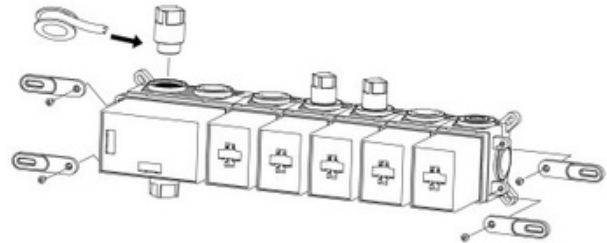

Step 1: Install 4 fixed brackets in a concealed manner, and seal the threaded connection with raw tape.

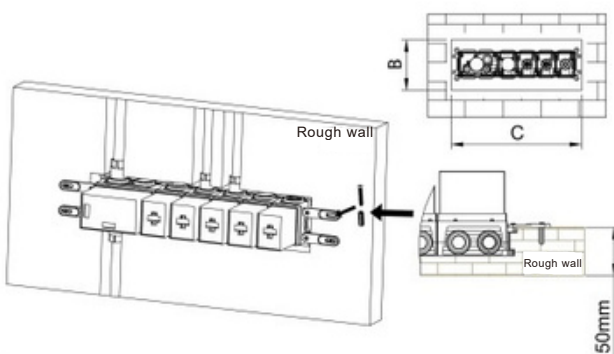

Step 2: Drill rough wall holes (with a slot depth of approximately 50mm) according to the maximum external dimensions of the pre embedded box, Secure the 4 fixed brackets with self tapping screws, connect the water pipe, and open the main valve to observe for any leakage

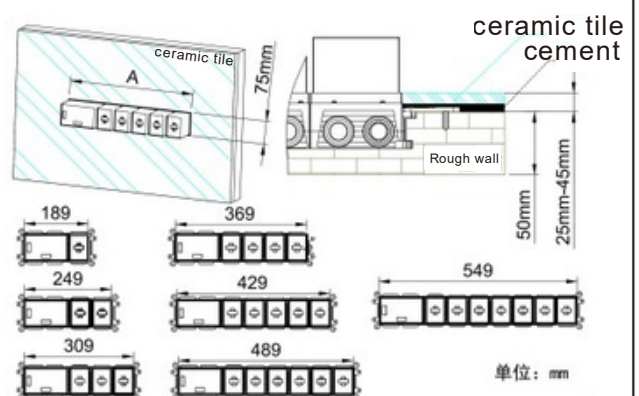

Step 3: According to the box shape shown in the figure below. open the tile hole size, and the total height of cement and tiles should be between 25-45mm

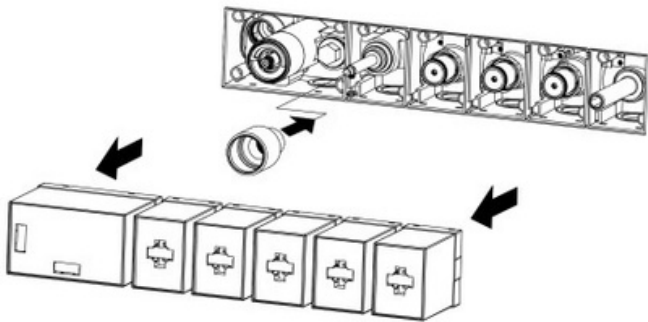

Step 4: Remove the protective cover (for the dual hand wheel model, the water distribution valve core should be fitted)

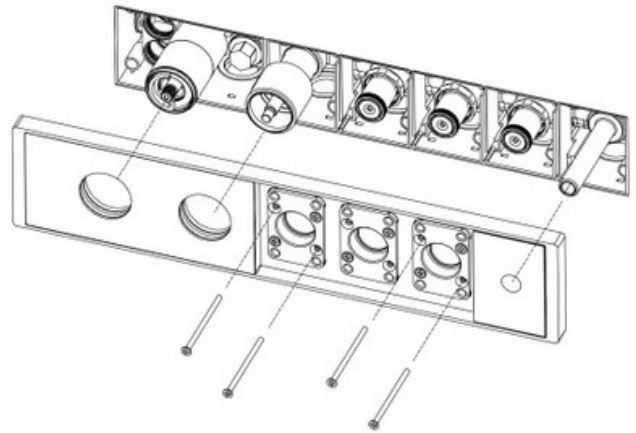

Step 5: Install the panel and attach the fixing screws

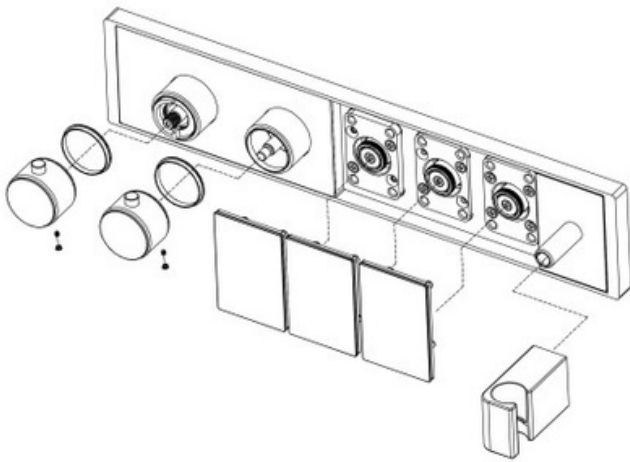

Step 6: Press the valve core to the closed state and adjust the nut with a measuring ruler (by manually turning the nut) Align with the bottom of the measuring scale (if there is any protrusion or concavity after placing the button panel, it can be fine tuned)

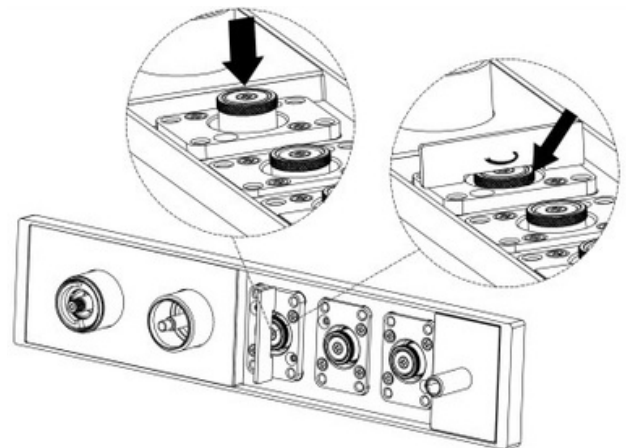

Step 7: Install the handwheel (note that the button is fixed to the water distribution handwheel), button panel, and showerhead bracket

◆ Install The rain shower Head

For wall mounted showers

Step 1

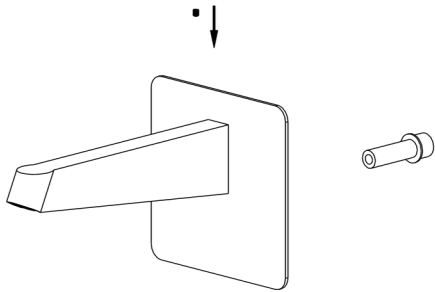

Step 1: Wind the waterproof belt around the water outlet joint and connect it to the water outlet pipe, and then connect the straight pipe with the water outlet joint the hexagon screw.

Step 2

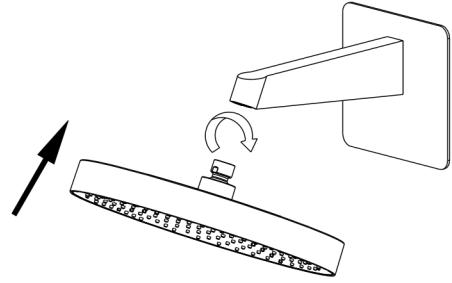

Step 2: Connect the top spray device to the straight pipe.

Install the handheld shower head

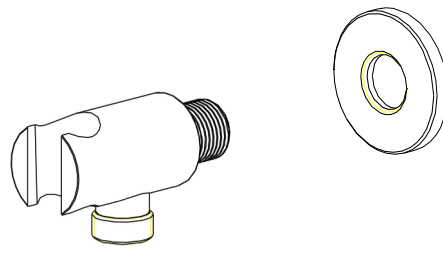

Step 1: After wrapping the waterproof belt around the hand shower fixing base, align the decorative cover and the fixing base, and then rotate to screw it into the.



Step 2. Connect the handheld shower and bracket holder with the hose.
Make sure the rubber gaskets inside the hose





Inbouwdouche

Montage handleiding

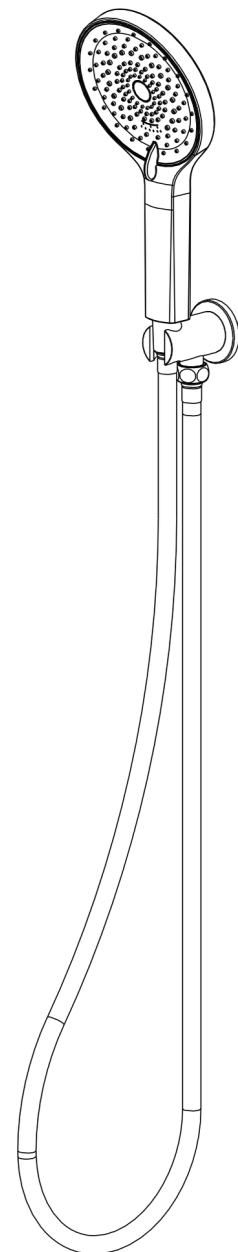
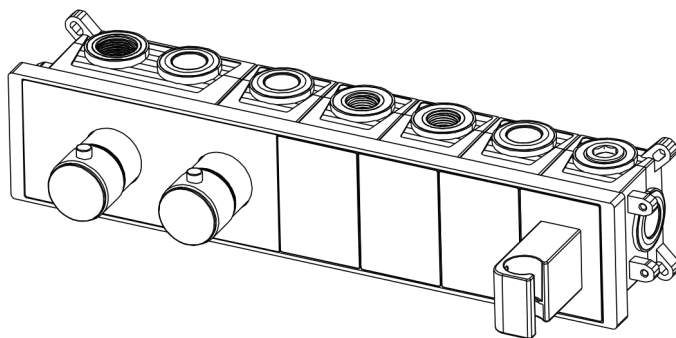
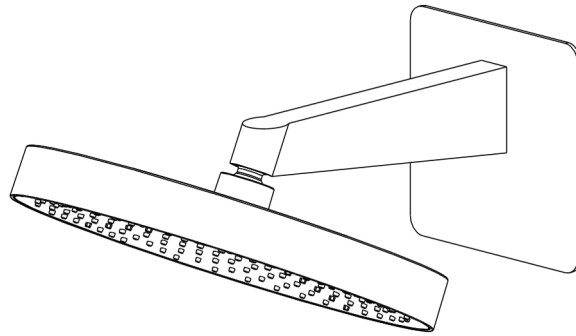



Bedankt dat u gekozen heeft voor ons LOMAZOO regendouchesysteem. Lees deze handleiding eerst goed door en bewaar hem, zodat u hem later altijd kunt raadplegen.

Technische vereisten

1. Zorg dat de waterdruk tussen 0,1 MPa en 1,0 MPa ligt.
2. Is de druk hoger dan 1,0 MPa, plaats dan een drukreducerend ventiel.
3. Spoel de leidingen goed door voordat u begint, om vuil en slib te verwijderen en verstoppingen of lekkages te voorkomen.
4. Dit systeem wordt in de muur ingebouwd.
5. Controleer de afmetingen in deze handleiding en markeer de juiste plaats op de muur.
6. Draai teflontape om de schroefdraad van de aanvoer- en afvoerleidingen.
7. Wikkel altijd met de klok mee een paar slagen om het schroefdraad, anders kan er lekkage ontstaan.
8. Zet de hoofdkraan dicht voordat u begint met de installatie.

Benodigde gereedschappen

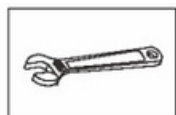

Verstelbare
moersleutel



Inbussleutel
(meegeleverd)

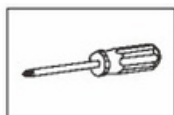

Kruiskopschroef
vendraaier



Teflontape

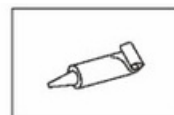

Lijm

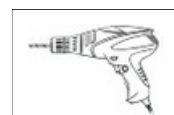

Elektrische boor

Controle van installatie accessoires

Controleer zorgvuldig of de benodigde accessoires in de verpakking is meegeleverd. Neem bij ontbrekende onderdelen direct contact op met LOMAZOO.

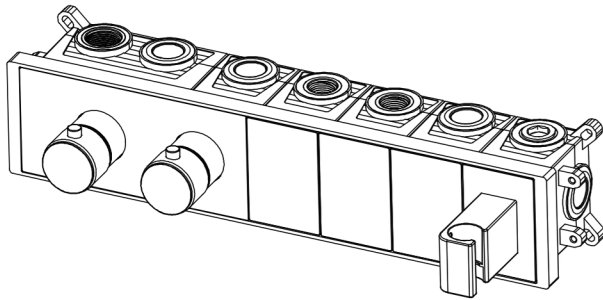

Installatie van het inbouwdeel van de douche

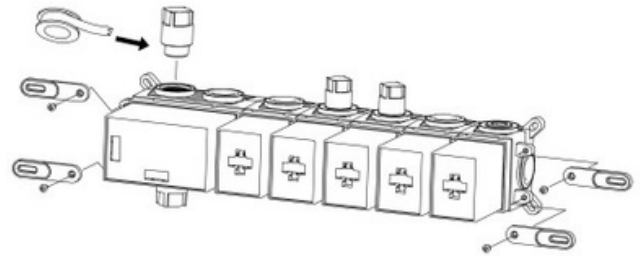

Stap 1:
Monteer 4 bevestigingsbeugels verdekt en dicht de schroefdraadverbinding af met teflontape.

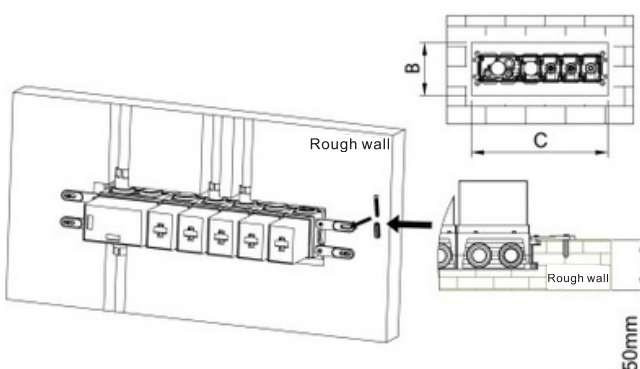

Stap 2:
Boor de uitsparingen in de muur (sleufdiepte ongeveer 50 mm) volgens de maximale buitenafmetingen van het inbouwdeel.
Zet de 4 bevestigingsbeugels vast met zelftappende schroeven.
Sluit de waterleiding aan en zet de hoofdkraan open om te controleren op lekkages.

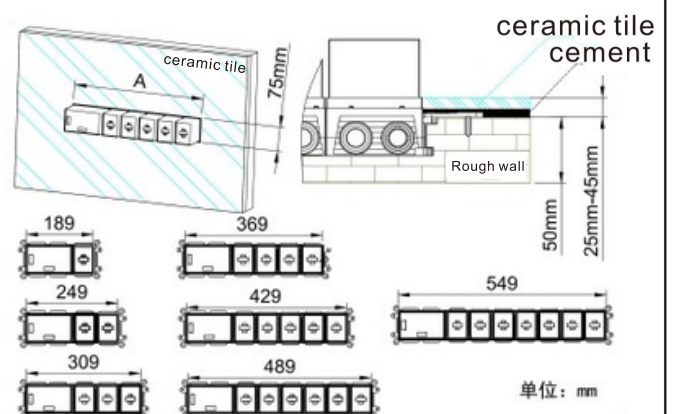

Stap 3:
Houd bij het maken van de uitsparing de vorm en afmetingen van het inbouwdeel aan zoals aangegeven in de tekening.
De totale hoogte van de cement- en tegellaag moet tussen 25 en 45 mm liggen.

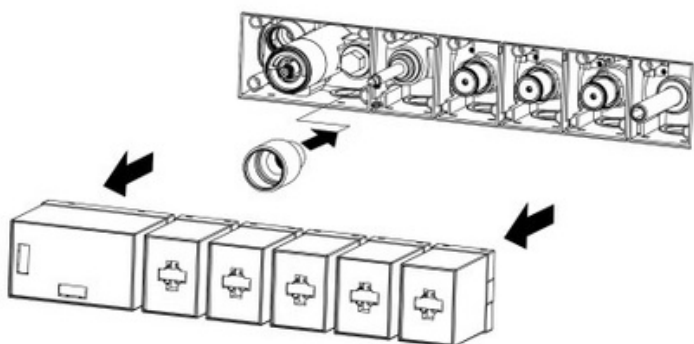

Stap 4:
 Verwijder de beschermkap.
 (Bij het model met dubbele draaiknop:
 plaats eerst het verdeelventiel
 binnenwerk.)

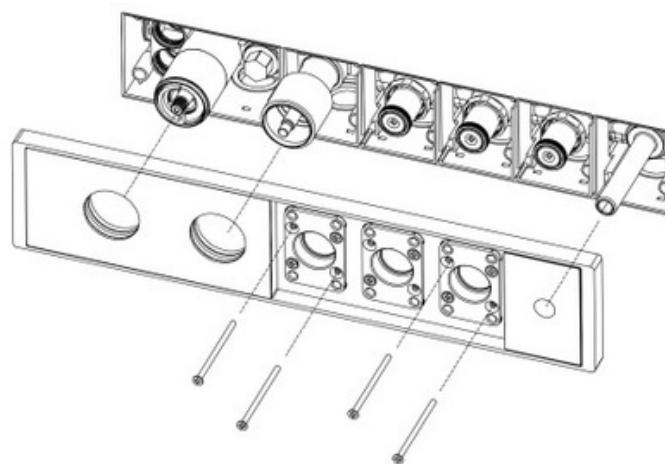

Stap 5:
 Monteer het afdekpaneel en zet het
 vast met de bevestigingsschroeven.

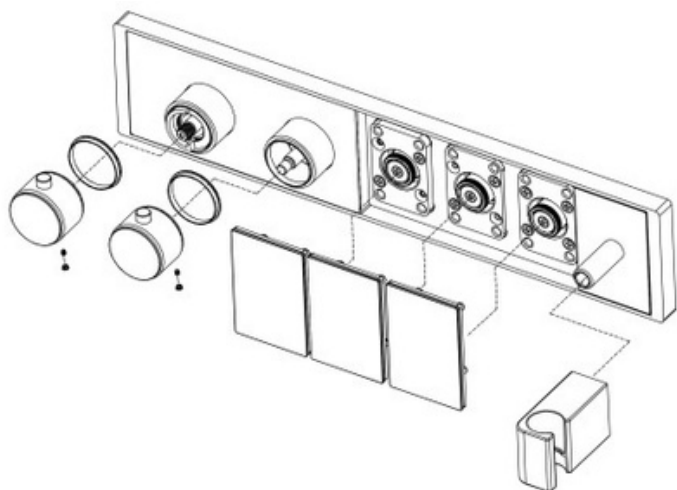

Stap 6:
 Zet het verdeelventiel in de gesloten
 stand en stel de moer af met een
 meetlat (draai de moer met de hand).
 Lijn de onderzijde uit met de onderkant
 van de schaalverdeling.
 Als het paneel na plaatsing uitsteekt of
 iets verzonken ligt, kan dit naderhand
 fijn afgesteld worden.

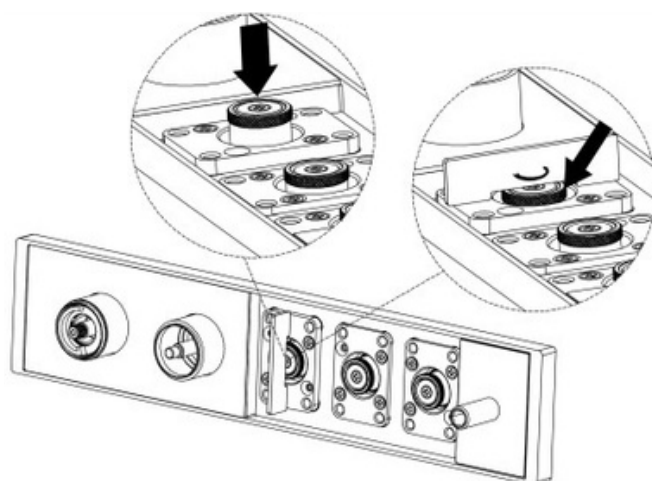

Stap 7:
 Monteer de bedieningsknop (let erop
 dat de knop wordt bevestigd aan het
 verdeelventiel), het afdekpaneel en de
 houder voor de douchekop.

Montage van de regendouchekop

For wall mounted showers

Step 1

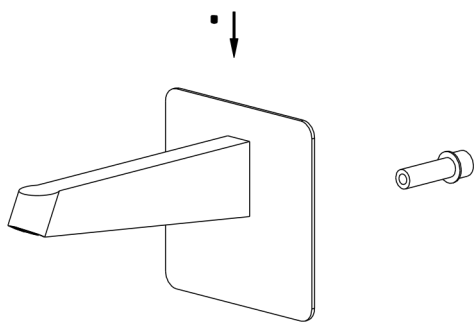

Stap 1: Wikkel teflontape om de schroefdraad van het aansluitpunt in de muur. Schroef daarna de rechte pijp vast op dit aansluitpunt met de inbusleutel.

Step 2

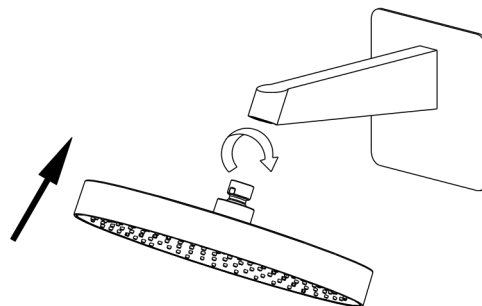

Stap 2: Bevestig de regendouchekop aan de douche arm.

Montage van de handdouche

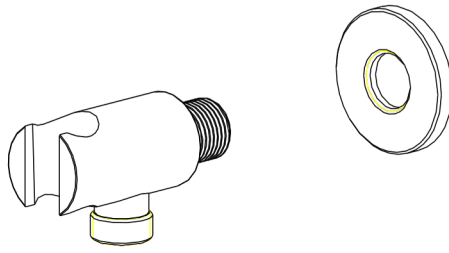

Stap 1: Doe teflontape om de schroefdraad van de houder voor de handdouche. Schuif de sierkap erover en draai de houder vast.

Stap 2: Bevestig de handdouche aan de houder met de doucheslang. Controleer of de rubberen ringetjes in de slang zitten.





Systeme de doucheencastré

Guide d'installation

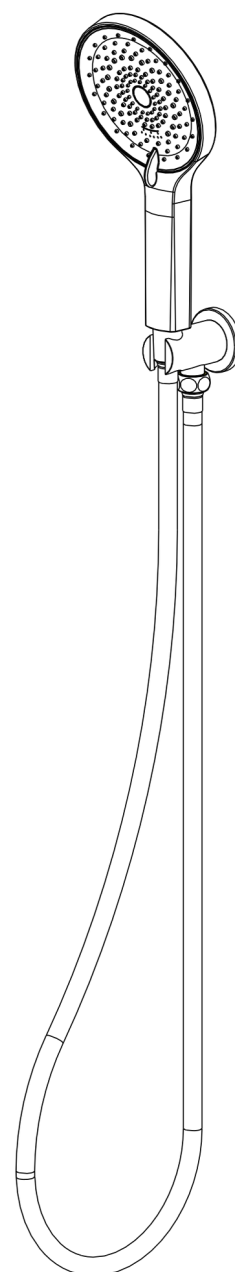
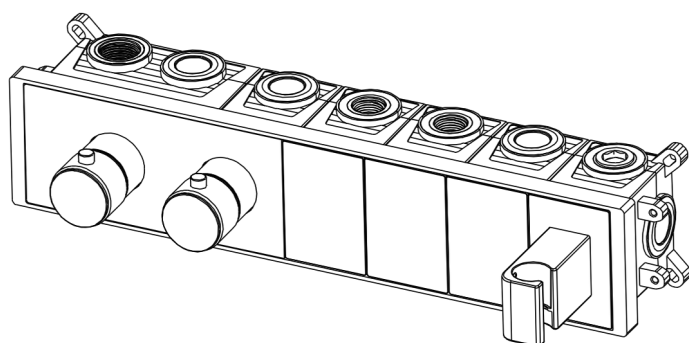
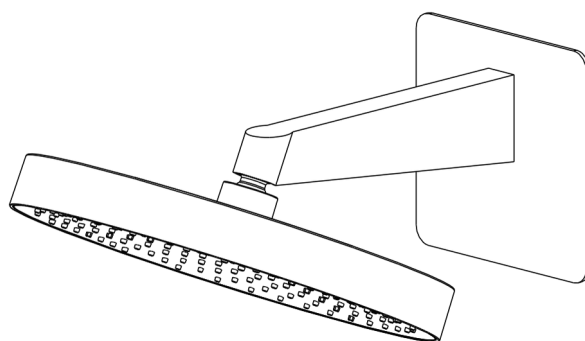



Merci d'avoir choisi notre douche encastrée. Lisez bien ce guide avant de commencer et gardez-le pour pouvoir le consulter plus tard.

Exigences techniques

1. La pression d'eau doit être entre 0,1 MPa et 1,0 MPa.
2. Si elle est supérieure à 1,0 MPa, installez un réducteur de pression.
3. Rincez bien les tuyaux avant l'installation pour éviter les fuites ou les bouchons.
4. Ce système doit être encastré dans le mur.
5. Vérifiez les dimensions indiquées dans ce guide et marquez l'emplacement sur le mur.
6. Enroulez du ruban téflon autour du filetage des arrivées et sorties d'eau.
7. Toujours enrouler dans le sens des aiguilles d'une montre, sinon il y aura des fuites.
8. Coupez l'arrivée d'eau avant de commencer l'installation.

Outils nécessaires

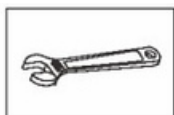

Clé à molette réglable



Clé Allen (fournie)

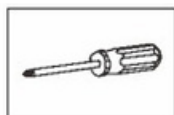

Tournevis cruciforme



Ruban téflon

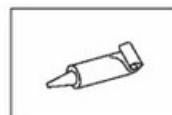

Colle

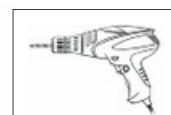

Perceuse électrique

Vérification des accessoires

Vérifiez bien que tous les accessoires nécessaires sont fournis dans l'emballage. S'il manque quelque chose, contactez immédiatement LOMAZOO.

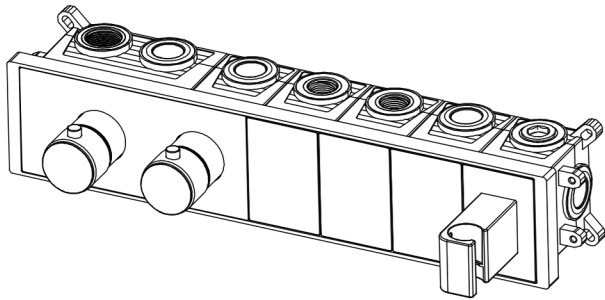

Installation du boîtier encastré

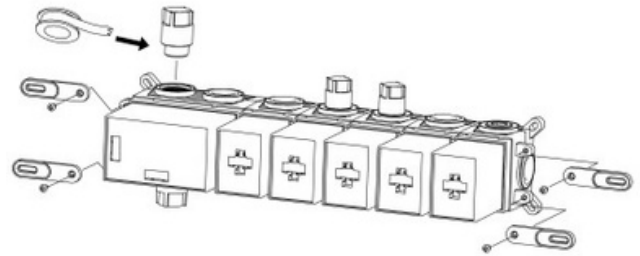

Étape 1 :
Fixez quatre supports de montage dissimulés et scellez les filetages avec du ruban téflon.

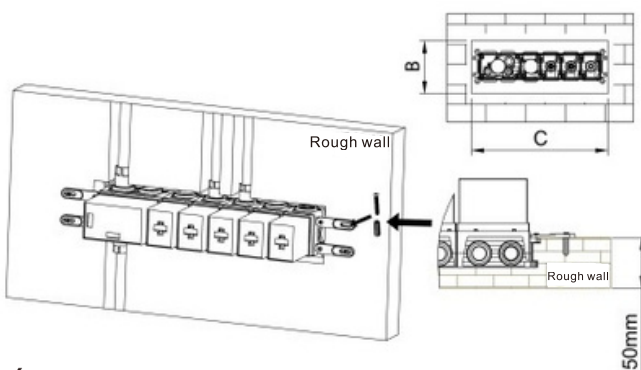

Étape 2 :
Percez les ouvertures dans le mur (profondeur d'environ 50 mm) selon les dimensions extérieures maximales du boîtier encastré.
Fixez les quatre supports à l'aide de vis autotaraudeuses.
Raccordez l'alimentation en eau et ouvrez la vanne principale pour vérifier l'absence de fuites.

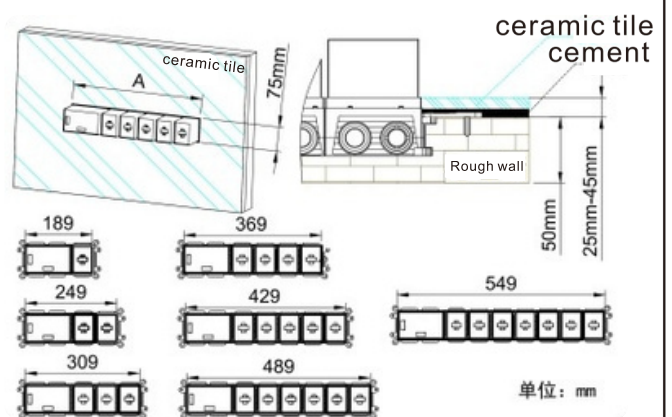

Étape 3 :
Lors de la découpe de l'ouverture, respectez la forme et les dimensions indiquées dans le schéma.
L'épaisseur totale de la couche de ciment et du carrelage doit être comprise entre 25 mm et 45 mm.

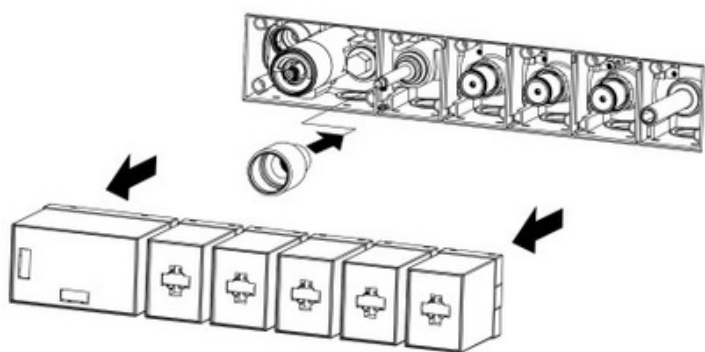

Étape 4 :
Retirez le cache de protection du boîtier encastré.
(Pour les modèles à double commande : installez d'abord la cartouche de l'inverseur.)

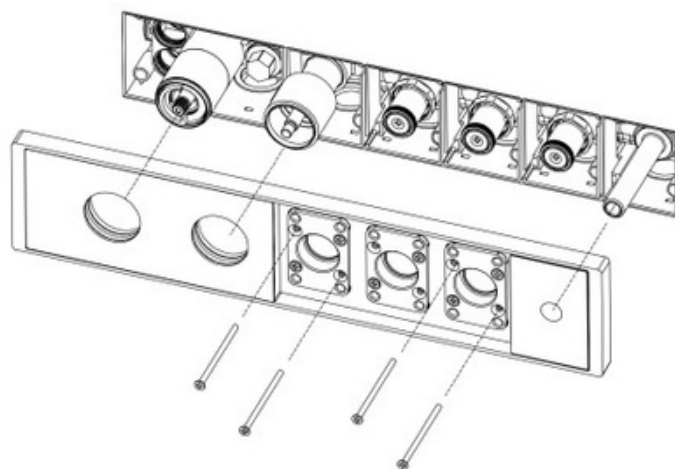

Étape 5 :
Placez le panneau de finition et fixez-le avec les vis fournies.

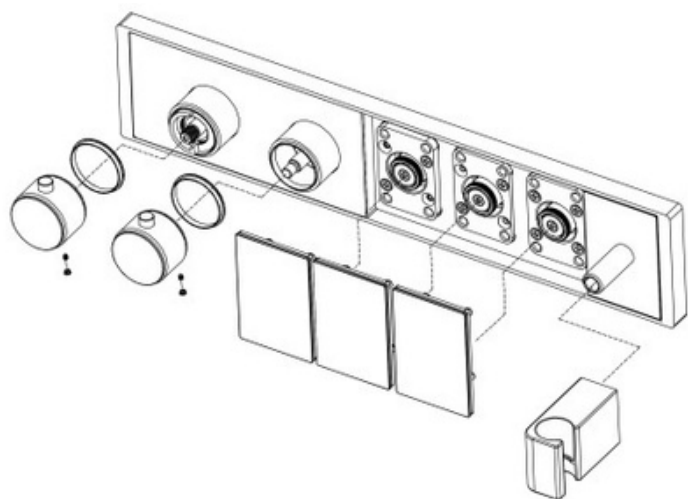

Étape 6 :
Mettez l'inverseur en position fermée.
Ajustez l'écrou à l'aide d'une règle (tourner à la main) pour que le bord inférieur soit aligné avec le repère de l'échelle.
Si, après montage, le panneau dépasse ou est trop en retrait, il est possible de régler à nouveau plus tard.

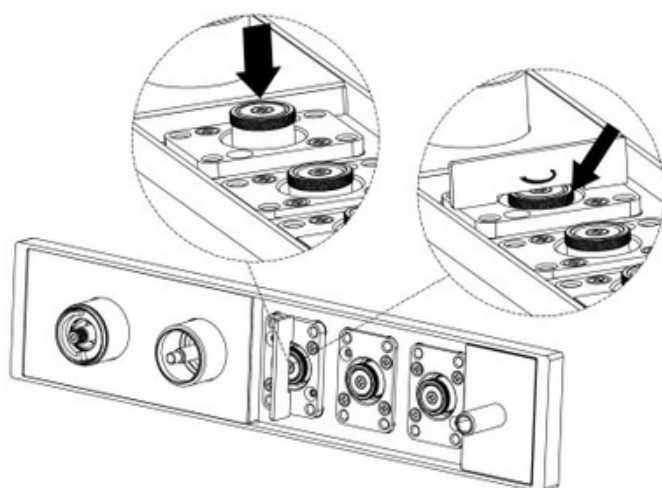

Étape 7 :
Montez la poignée de commande (veillez à ce qu'elle soit fixée sur l'inverseur), installez la plaque décorative et fixez le support de la douchette à main

Montage de la douche de tête

For wall mounted showers

Étape 1

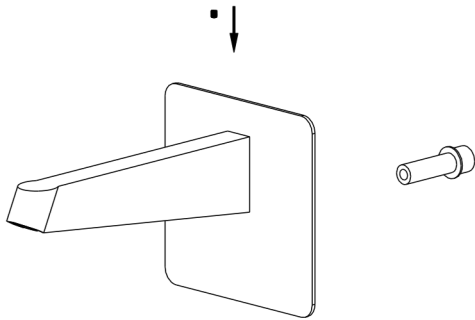

Étape 1 :
Enroulez du ruban téflon autour du filetage du raccord mural.
Vissez ensuite le bras de douche sur ce raccord avec la clé Allen.

Étape 2

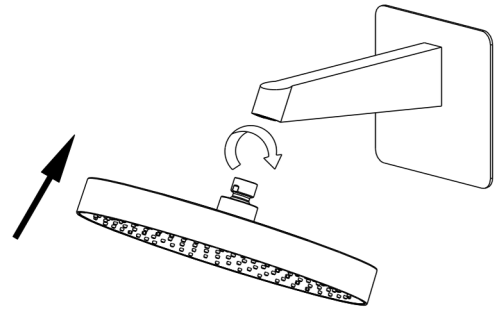

Étape 2 :
Fixez la douche de tête sur le bras de douche.

Montage de la douchette à main

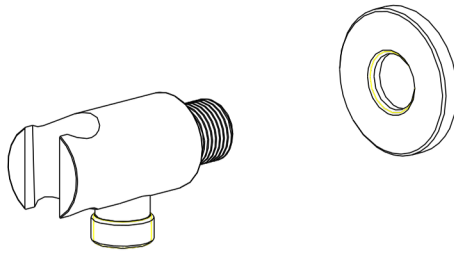

Étape 1 :

Enroulez du ruban téflon autour du filetage du raccord mural.

Vissez ensuite le bras de douche sur ce raccord avec la clé Allen.

Étape 2 :

Fixez la douche de tête sur le bras de douche.

