

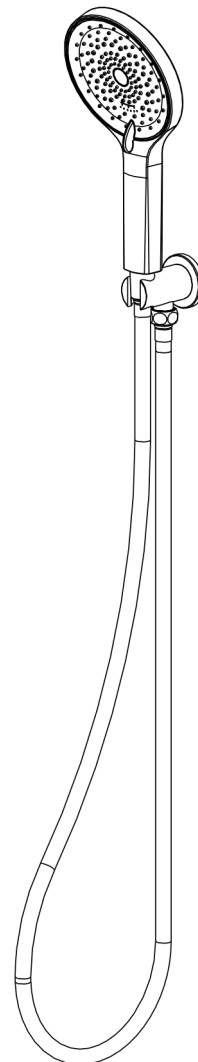

# Einbaudusche

# Montageanleitung

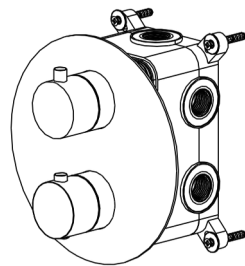

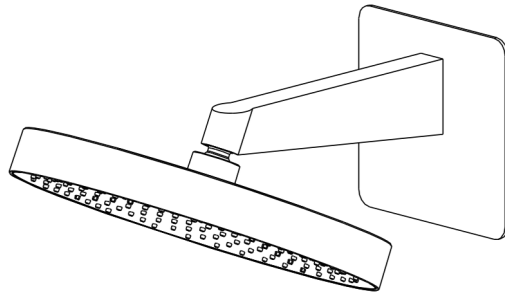

Vielen Dank, dass Sie sich für unsere Unterputzdusche entschieden haben.

Lesen Sie diese Anleitung vor Beginn der Arbeiten sorgfältig durch und bewahren Sie sie auf, damit Sie später jederzeit etwas nachschlagen können.

## Technische Anforderungen

1. Der Wasserdruck muss zwischen 0,1 MPa und 1,0 MPa liegen.
2. Liegt der Druck über 1,0 MPa, muss ein Druckminderereingebaut werden.
3. Spülen Sie die Leitungen gründlich durch, bevor Sie beginnen, damit kein Schmutz oder Schlamm Undichtigkeiten oder Verstopfungen verursacht.
4. Dieses System wird in die Wand eingebaut.
5. Überprüfen Sie zuerst die Maße in dieser Anleitung und markieren Sie die genaue Position an der Wand.
6. Wickeln Sie Teflonband um das Gewinde der Zu- und Ablaufleitungen.
7. Immer im Uhrzeigersinn ein paar Lagen wickeln, sonst kann es zu Undichtigkeiten kommen.
8. Drehen Sie den Haupthahn zu, bevor Sie mit der Installation beginnen.

## Benötigtes Werkzeug

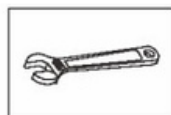

Verstellbarer  
Schraubenschlüssel



Innensechskantschlüssel  
(mitgeliefert)

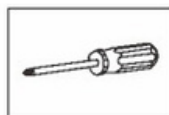

Kreuzschlitzzschraubendreher



Teflonband

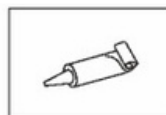

Kleber

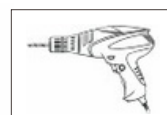

Elektrische  
Bohrmaschine

## Überprüfung des Zubehörs

Prüfen Sie genau, ob sämtliches benötigtes Zubehör im Lieferumfang enthalten ist. Falls etwas fehlt, setzen Sie sich sofort mit LOMAZOO in Verbindung.



## (Empfohlene Wandstärke)

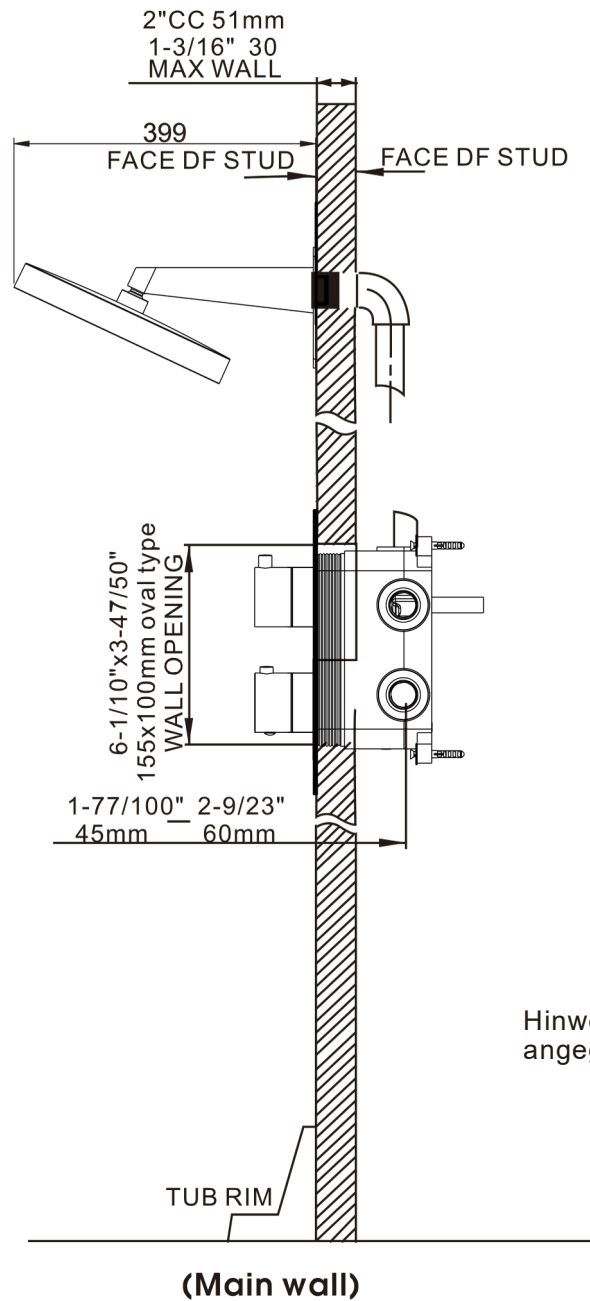

(Maße für die  
Wandaussparung)

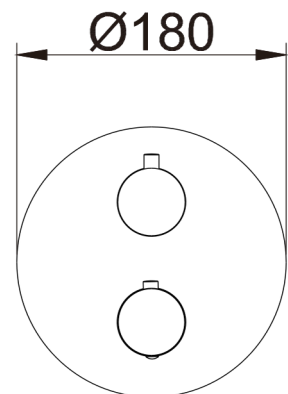
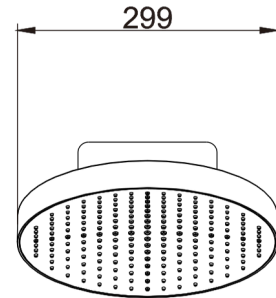

Hinweis: Maße sind in Millimetern oder Zoll angegeben.



## Montage der Installation der Einbaudusche

Stellen Sie sicher, dass die Mischbatterie korrekt an die richtige Warm- und Kaltwasserseite angeschlossen wird.

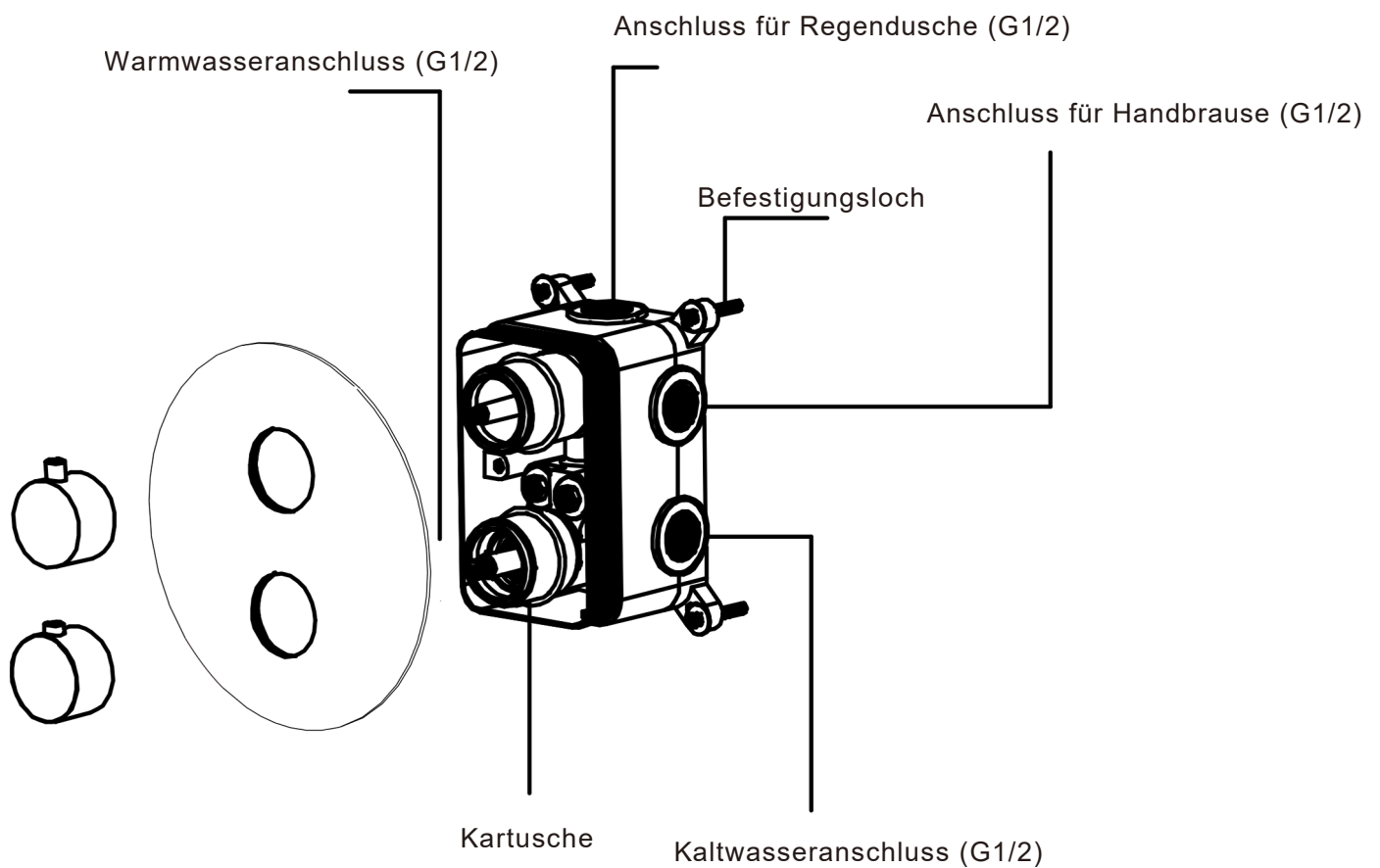

# Installatie stappen

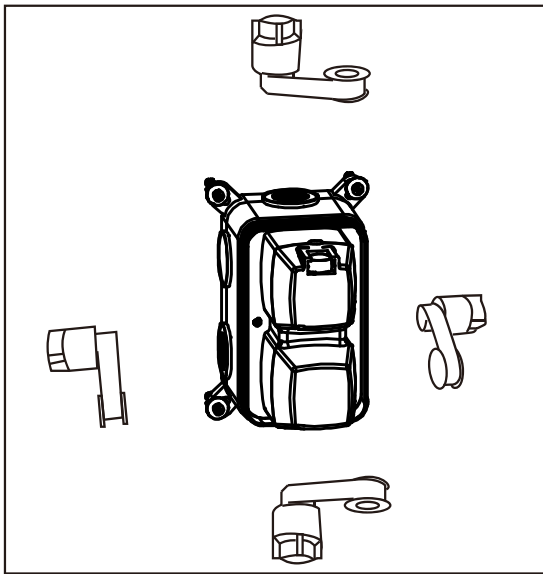

Schritt 1:  
Ummanteln Sie die Zu- und Ablaufleitungen mit Teflonband. Wickeln Sie das Teflonband einige Male im Uhrzeigersinn um das Gewinde der Leitungen.

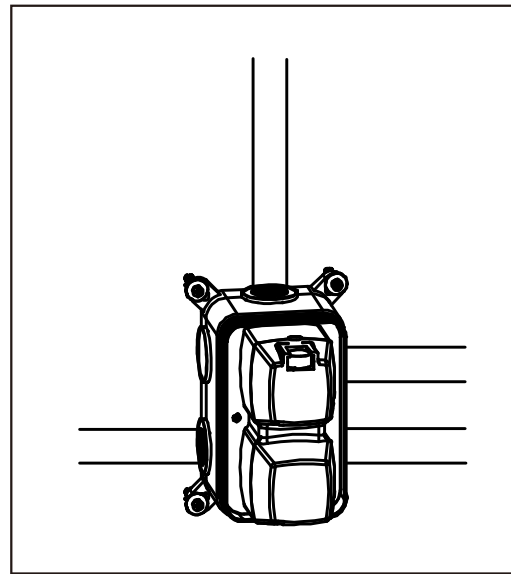

Schritt 2:  
Schließen Sie die Wasserleitungen an die Unterputzbox an.

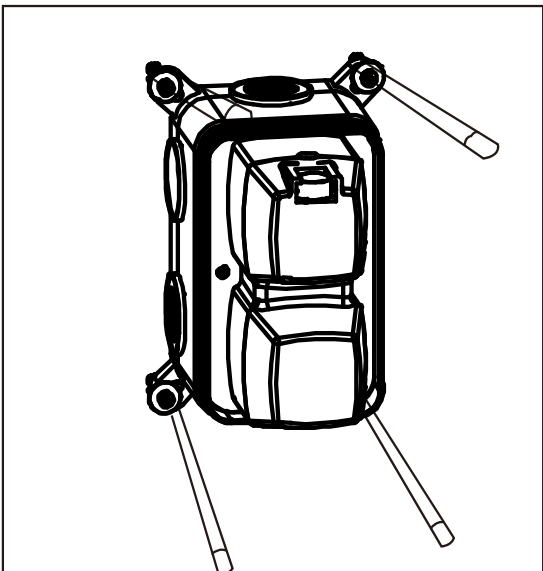

Schritt 3:  
Bestimmen Sie die Position der Unterputzbox und der Leitungen und markieren Sie diese.

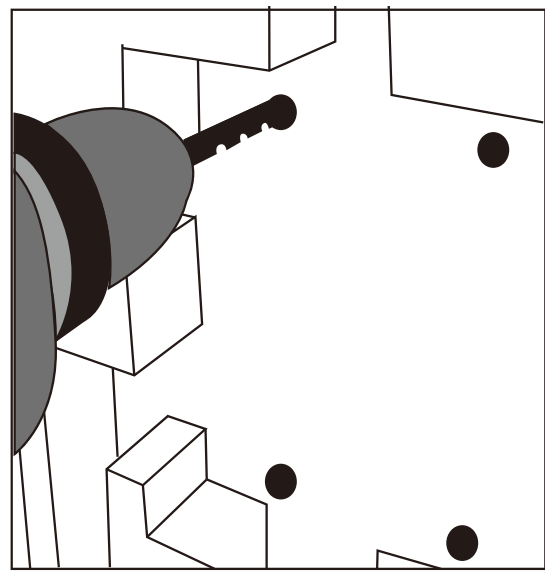

Schritt 4:  
Nachdem die Position festgelegt wurde, stemmen Sie die Schlitz für die Leitungen aus. Entfernen Sie die Unterputzbox und bohren Sie die Löcher. Verwenden Sie anschließend eine elektrische Bohrmaschine, um die weißen Schrauben (③) in die Wand zu setzen.

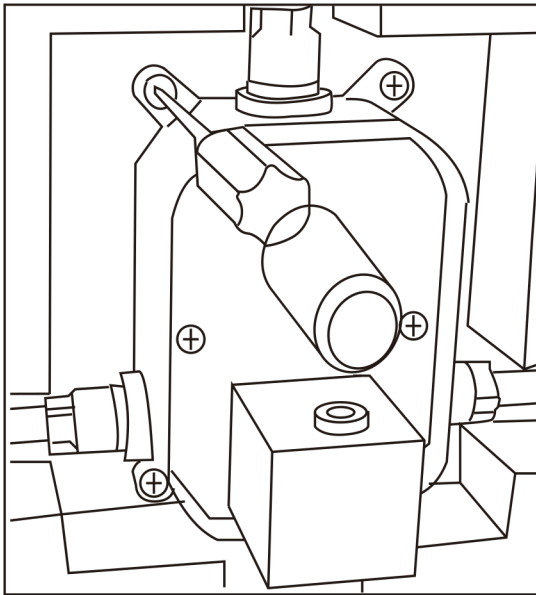

Schritt 5:  
Unterputzbox mit vier Schrauben an der Wand befestigen.

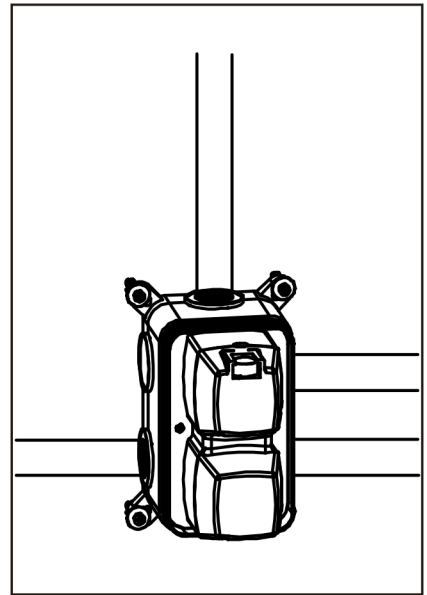

Schritt 6:  
Abdeckung der Unterputzbox am Mischventil abnehmen.  
Mit dem Bedienhebel jede Zu- und Ablaufleitung einem Drucktest unterziehen, um Undichtigkeiten zu prüfen.

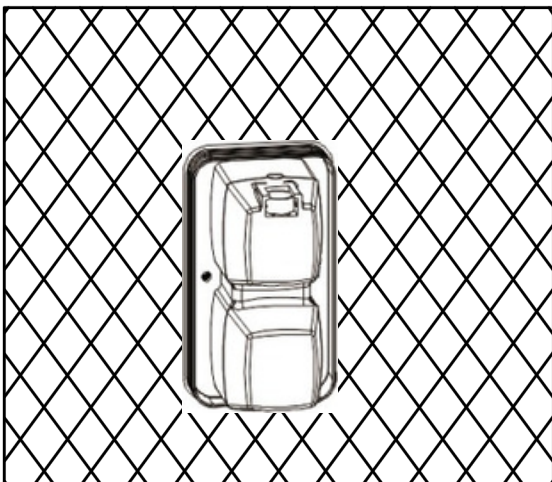

Schritt 7:  
Unterputzbox mit einer Abdeckung gegen Staub und Schmutz schützen, bis die Wand fertig verfliest ist.

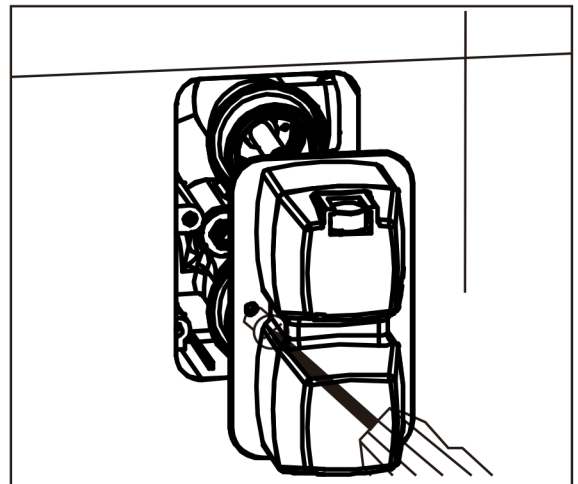

Schritt 8:  
Nach dem Verfliesen der Wand die Abdeckung der Unterputzbox entfernen.

# Installation der Blende

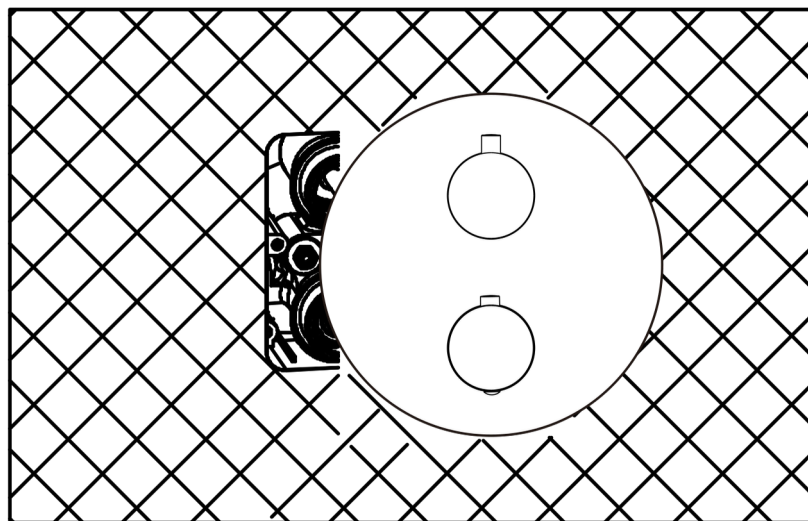

Schritt 1

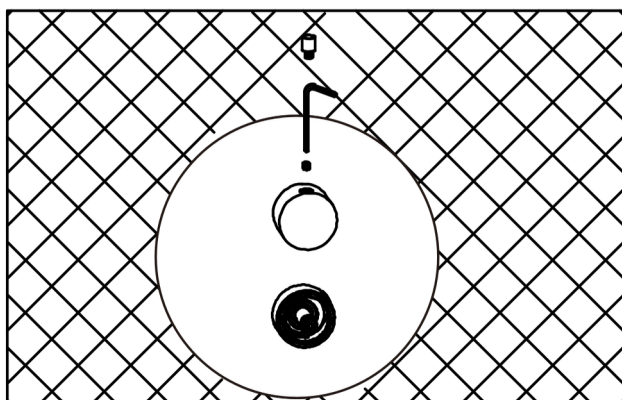

Schritt 2

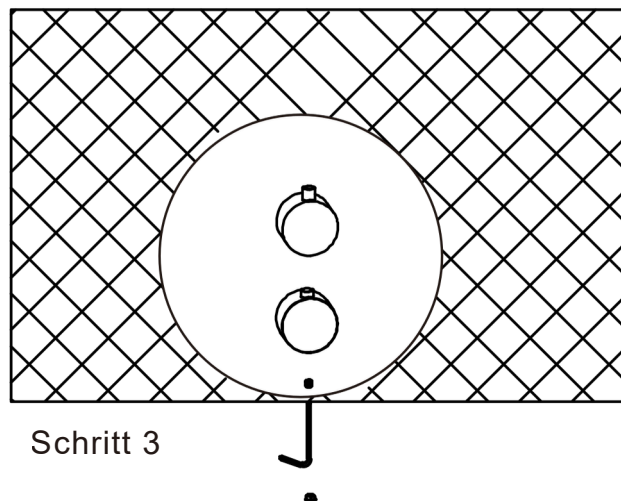

Schritt 3

Schritt 1:

Abdeckplatte über die Unterputzbox setzen.

Schritt 2:

Bedienknopf für die Regendusche mit einer Inbusschraube und einer kleinen Abdeckkappe befestigen.

Schritt 3:

Einhebelgriff mit einer Inbusschraube und einer kleinen Abdeckkappe befestigen.

# Installation des Regenduschkopfs

For wall mounted showers

Schritt 1

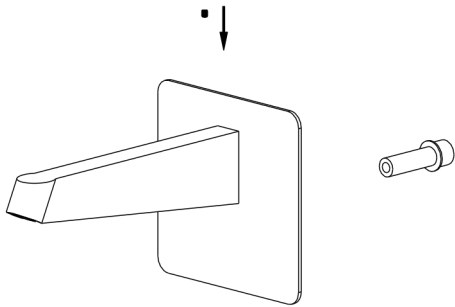

Schritt 1:  
Teflonband im Uhrzeigersinn um das Gewinde des Wandanschlusses wickeln.  
Anschließend den Duscharm mit dem Wandanschluss verschrauben und mit dem Inbusschlüssel festziehen.

Schritt 2

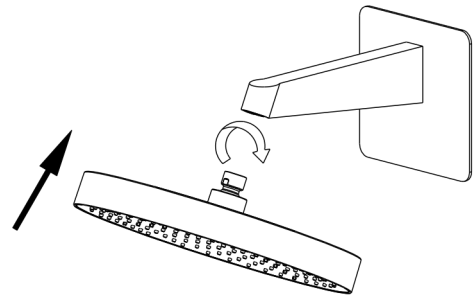

Schritt 2:  
Regenduschkopf am Duscharm befestigen.

# Montage der Handbrause

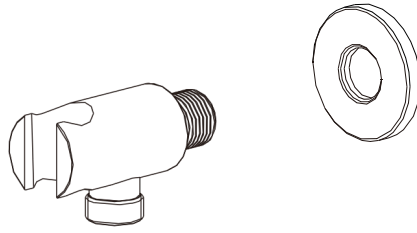

Schritt 1:  
Teflonband im Uhrzeigersinn um das Gewinde der Halterung für die Handbrause wickeln.  
Rosette (Zierabdeckung) aufschieben und die Halterung festschrauben



Schritt 2:  
Handbrause mit dem Brauseschlauch an der Halterung befestigen.  
Prüfen, ob die Gummidichtungen im Schlauch richtig sitzen.



## ◆ Regendusche- / Handbrause-Umschalter

Schalter auf das „Top Shower“-Symbol stellen für den Regenduschen-Modus.

Schalter auf das „Hand Shower“-Symbol stellen für den Handbrausen-Modus.

## ◆ Temperaturregler

Symbol „H“ steht für heißes Wasser, „C“ für kaltes Wasser.

Die Temperatur kann manuell eingestellt werden, indem der Griff zur H- oder C-Seite gedreht wird.

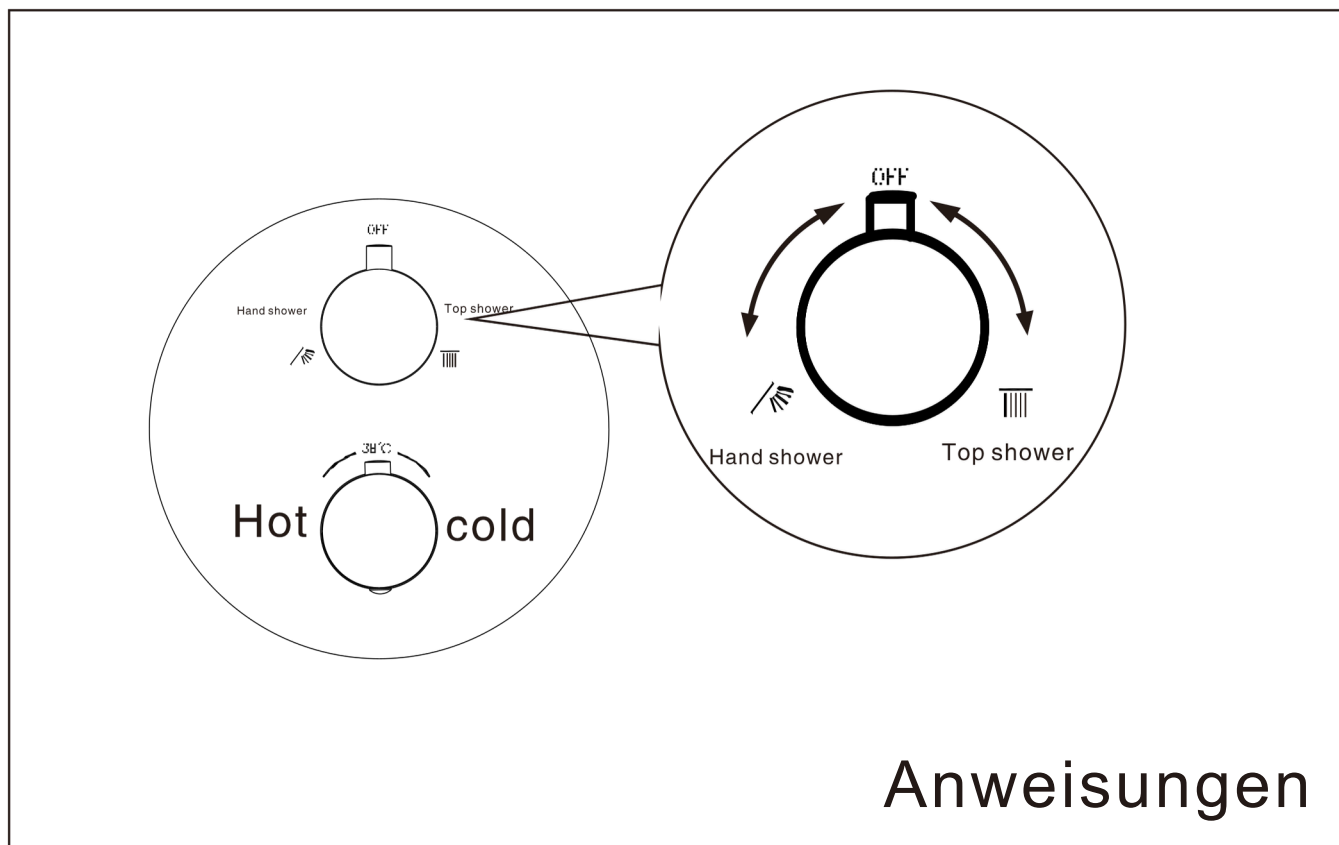

Damit Ihr Duschsystem stets in einwandfreiem Zustand bleibt, empfehlen wir eine regelmäßige Reinigung.

So reinigen Sie die Mischbatterie:

1. Mit Wasser und einem weichen Baumwolltuch den Schmutz abwischen.

2. Eines der folgenden Reinigungsmittel verwenden, um Schmutz zu entfernen:

■ Mildes Reinigungsmittel

■ Farbloser Reiniger

3. Nach der Reinigung alle Rückstände vom Reinigungsmittel entfernen und mit einem weichen Tuch trocknen.

◆ **Kein Poliermittel oder Reinigungsmittel mit groben Partikeln verwenden.**

◆ **Keine säurehaltigen oder aggressiven Reinigungsmittel verwenden.**



Systeme de doucheencastré

# Guide d'installation

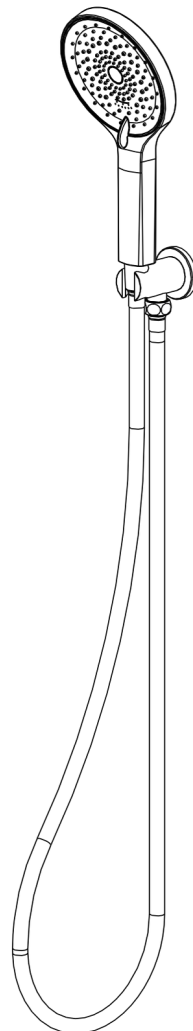
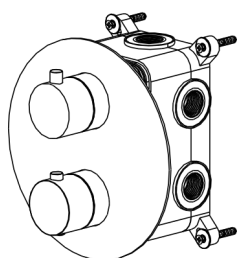
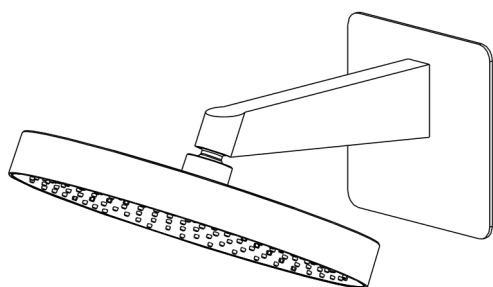

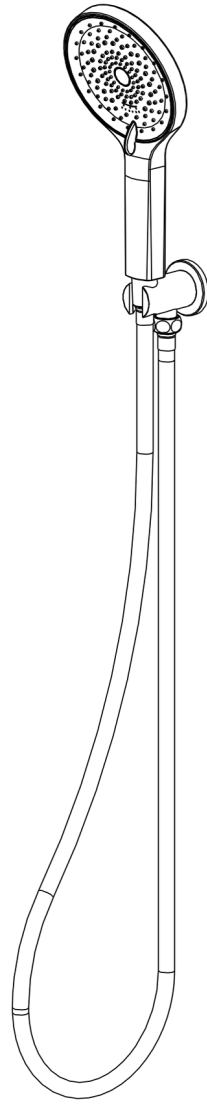
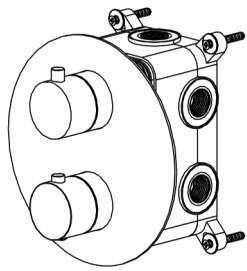
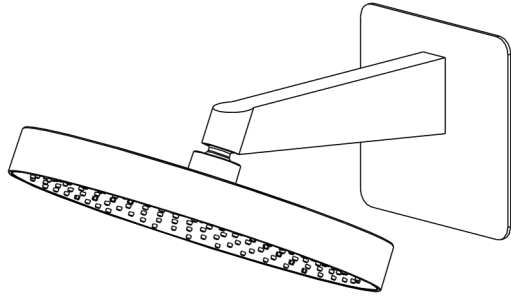



Merci d'avoir choisi notre douche encastrée. Lisez bien ce guide avant de commencer et gardez-le pour pouvoir le consulter plus tard.

## Exigences techniques

1. La pression d'eau doit être entre 0,1 MPa et 1,0 MPa.
2. Si elle est supérieure à 1,0 MPa, installez un réducteur de pression.
3. Rincez bien les tuyaux avant l'installation pour éviter les fuites ou les bouchons.
4. Ce système doit être encastré dans le mur.
5. Vérifiez les dimensions indiquées dans ce guide et marquez l'emplacement sur le mur.
6. Enroulez du ruban téflon autour du filetage des arrivées et sorties d'eau.
7. Toujours enrouler dans le sens des aiguilles d'une montre, sinon il y aura des fuites.
8. Coupez l'arrivée d'eau avant de commencer l'installation.

## Outils nécessaires

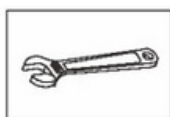

Clé à molette réglable



Clé Allen (fournie)

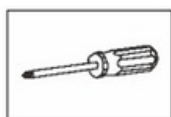

Tournevis cruciforme



Ruban téflon

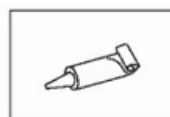

Colle

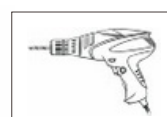

Perceuse électrique

## Vérification des accessoires

Vérifiez bien que tous les accessoires nécessaires sont fournis dans l'emballage. S'il manque quelque chose, contactez immédiatement LOMAZOO.



(Épaisseur de mur recommandée)

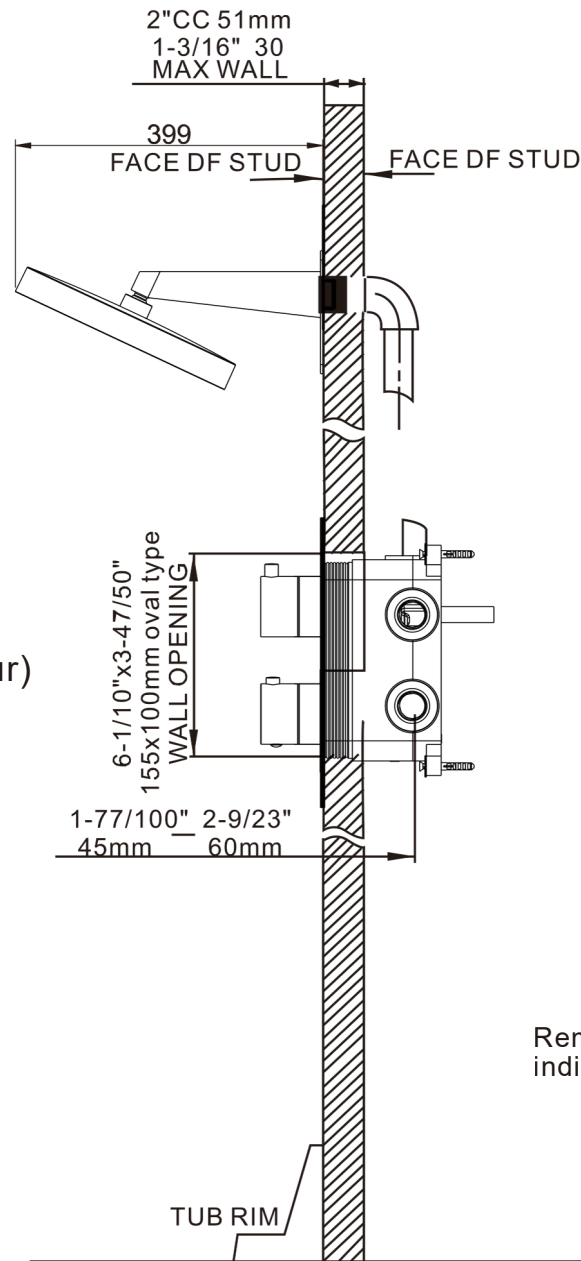

(Dimensions de la réservation dans le mur)

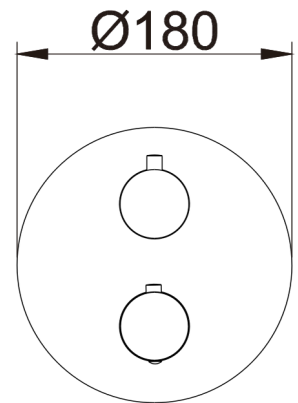
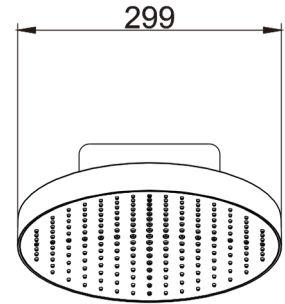

Remarque : Toutes les dimensions sont indiquées en millimètres et en pouces.



## Installation du boîtier encastré

Assurez-vous que le robinet mélangeur est bien raccordé du bon côté pour l'eau chaude et l'eau froide.

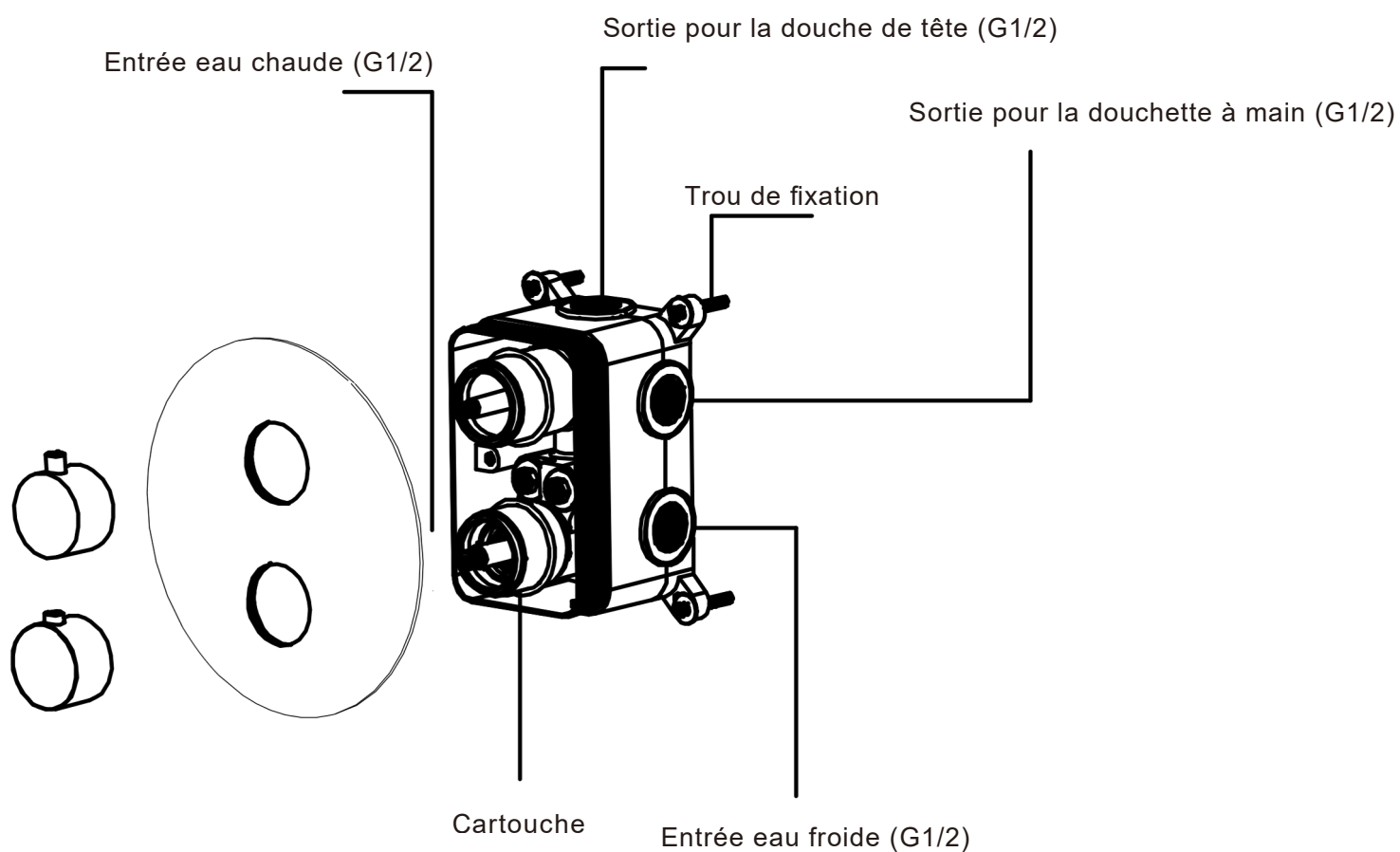

# Étapes d'installation

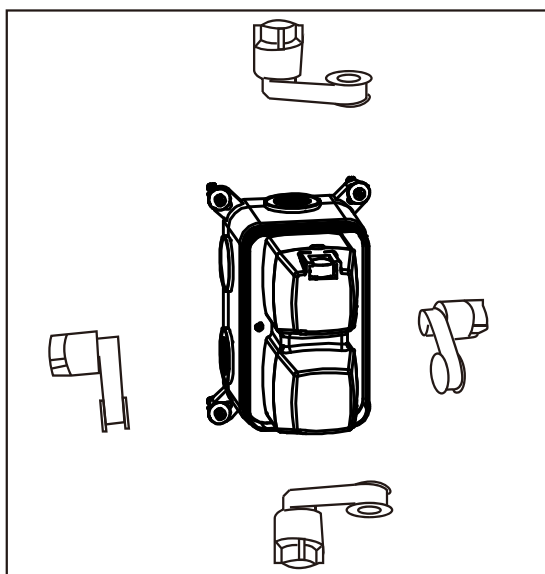

Étape 1 :  
Enroulez du ruban téflon autour du filetage des arrivées et sorties d'eau.  
Toujours enrouler dans le sens des aiguilles d'une montre pour éviter les fuites.

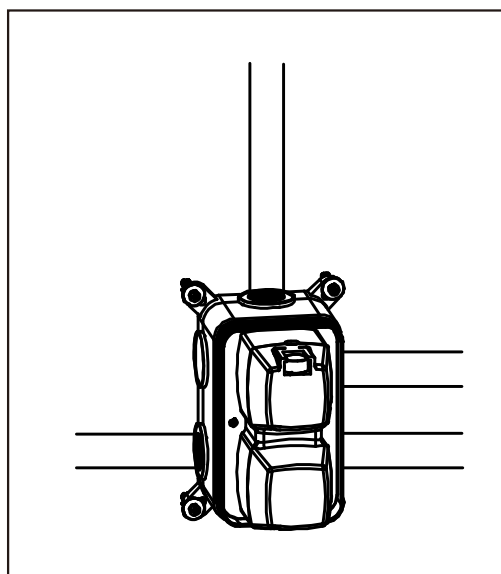

Étape 2 :  
Raccordez les tuyaux d'eau au boîtier encastré.

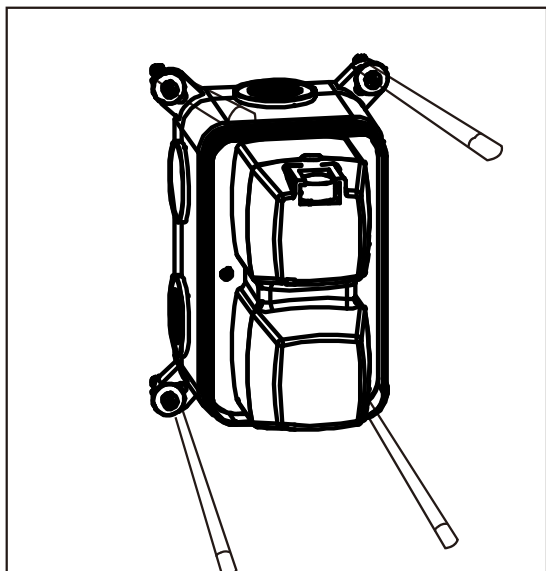

Étape 3 :  
Repérez et marquez la position du boîtier encastré et des tuyaux.

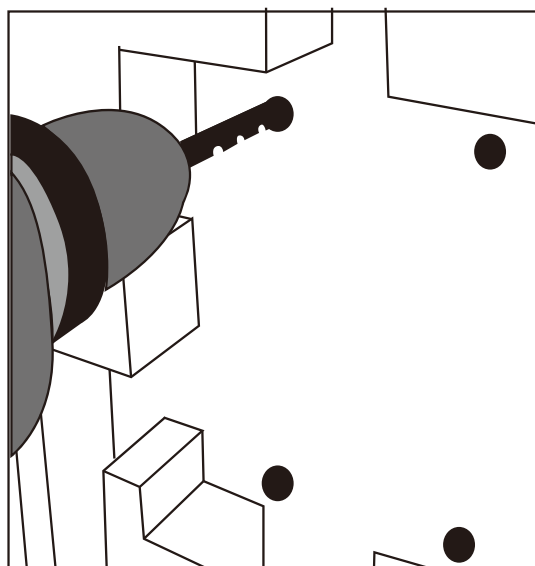

Étape 4 :  
Une fois la position définie, creusez les saignées pour les tuyaux.  
Retirez le boîtier encastré et percez les trous.  
Utilisez ensuite une perceuse pour fixer les vis lanches (3) dans le mur.

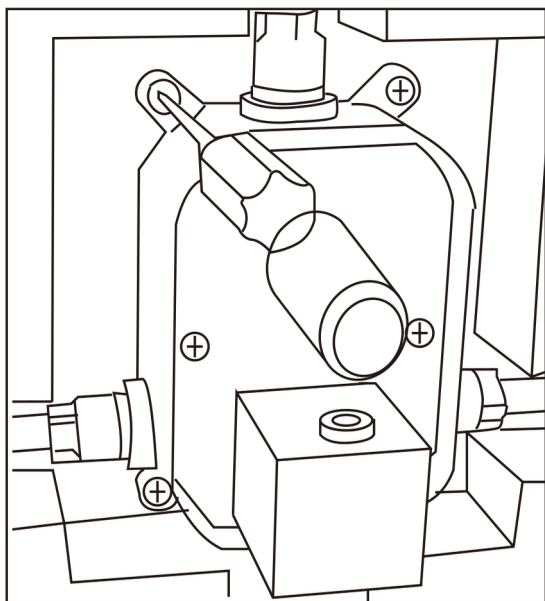

Étape 5 :  
Fixez le boîtier encastré au mur avec quatre vis.

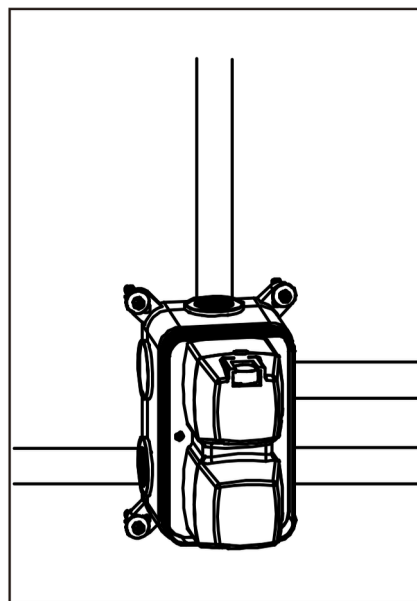

Étape 6 :  
Retirez le cache du boîtier encastré au niveau de la cartouche du robinet.  
Avec la poignée de commande, effectuez un test de pression sur chaque arrivée et sortie d'eau pour vérifier qu'il n'y a pas de fuites.

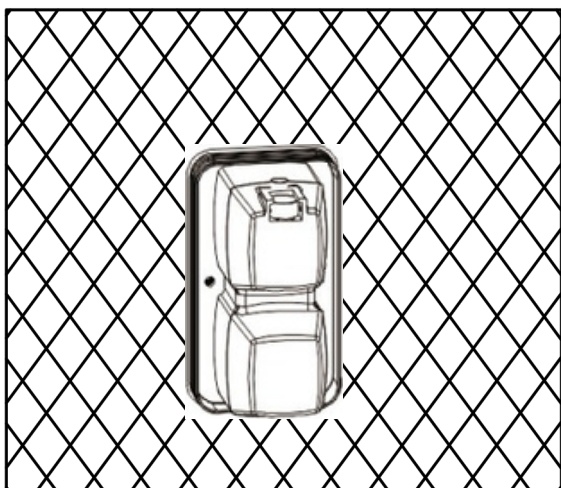

Étape 7 :  
Remettez un cache sur le boîtier encastré pour le protéger de la poussière pendant que le mur est carrelé.

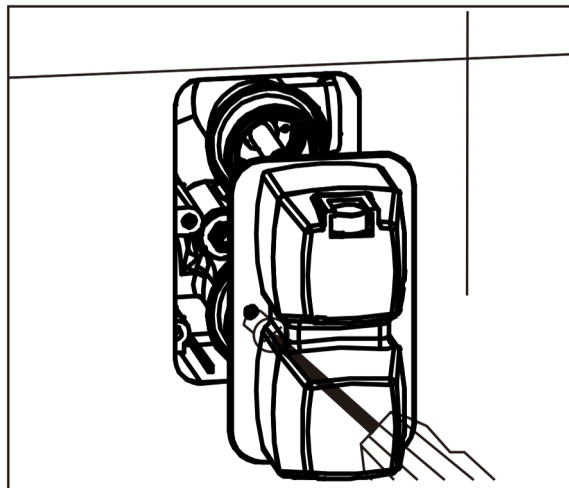

Étape 8 :  
Après avoir posé le carrelage, retirez le cache du boîtier encastré.

## Montage de la plaque de finition

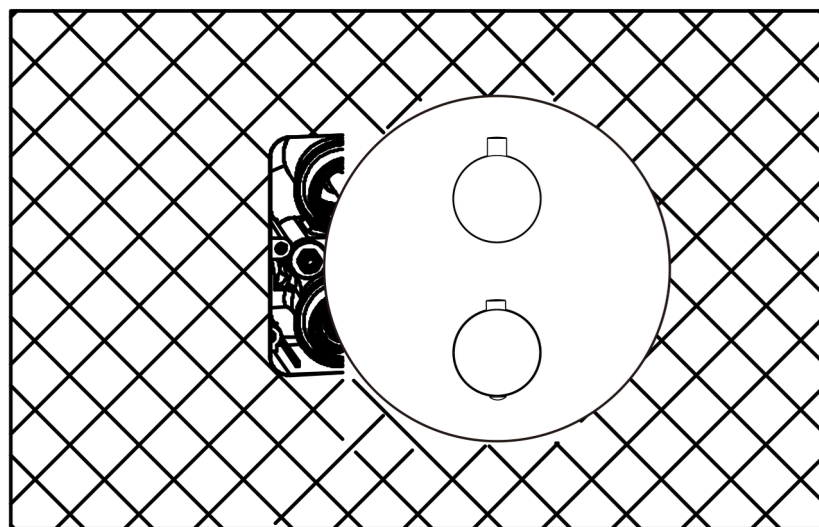

Étape 1

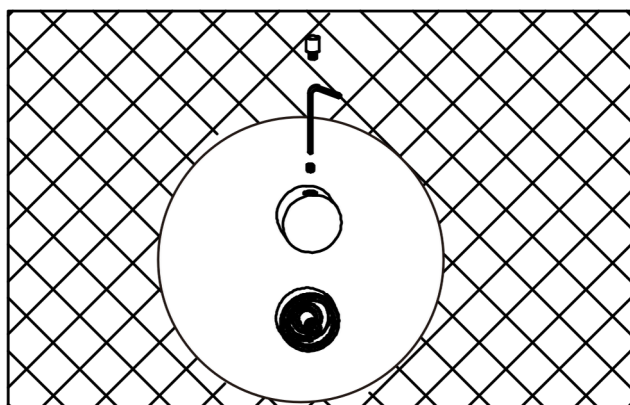

Étape 2

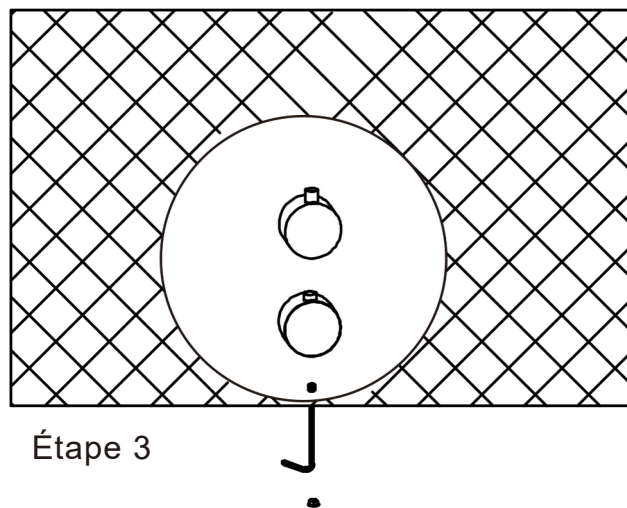

Étape 3

Étape 1 :

Placez la plaque de finition sur le boîtier encastré.

Étape 2 :

Fixez la commande de la douche de tête avec une vis BTR (clé Allen) et un petit cache.

Étape 3 :

Fixez la poignée monocommande avec une vis BTR et un petit cache

# Montage de la douche de tête

For wall mounted showers

Étape 1

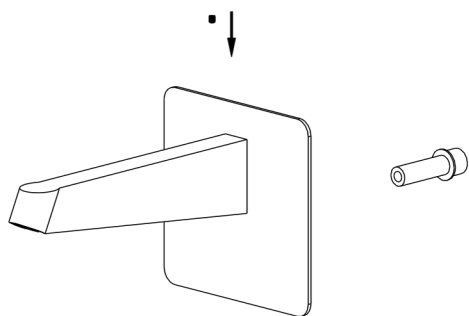

Étape 1 :  
Enroulez du ruban téflon autour du filetage du raccord mural.  
Vissez ensuite le bras de douche sur ce raccord avec la clé Allen.

Étape 2

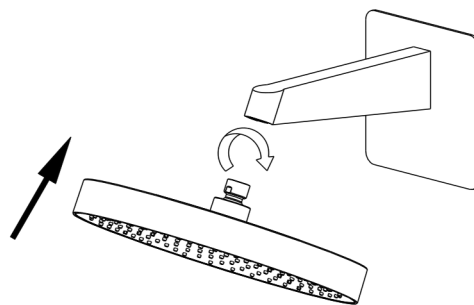

Étape 2 :  
Fixez la douche de tête sur le bras de douche.

## Montage de la douchette à main

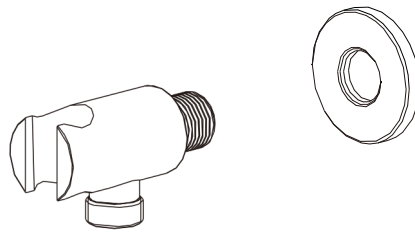

Étape 1 :  
Enroulez du ruban téflon autour du filetage du  
raccord mural.  
Vissez ensuite le bras de douche sur ce raccord  
avec la clé Allen.

Étape 2 :  
Fixez la douche de tête sur le bras de douche.





## ◆ Sélecteur douche de tête / douchette

Tournez le sélecteur vers le symbole « Top Shower » pour utiliser la douche de tête. Tournez-le vers le symbole « Hand Shower » pour utiliser la douchette à main.

## ◆ Commande de température

Le symbole « H » indique l'eau chaude, le symbole « C » indique l'eau froide. Tournez la poignée vers « H » ou « C » pour régler la température.

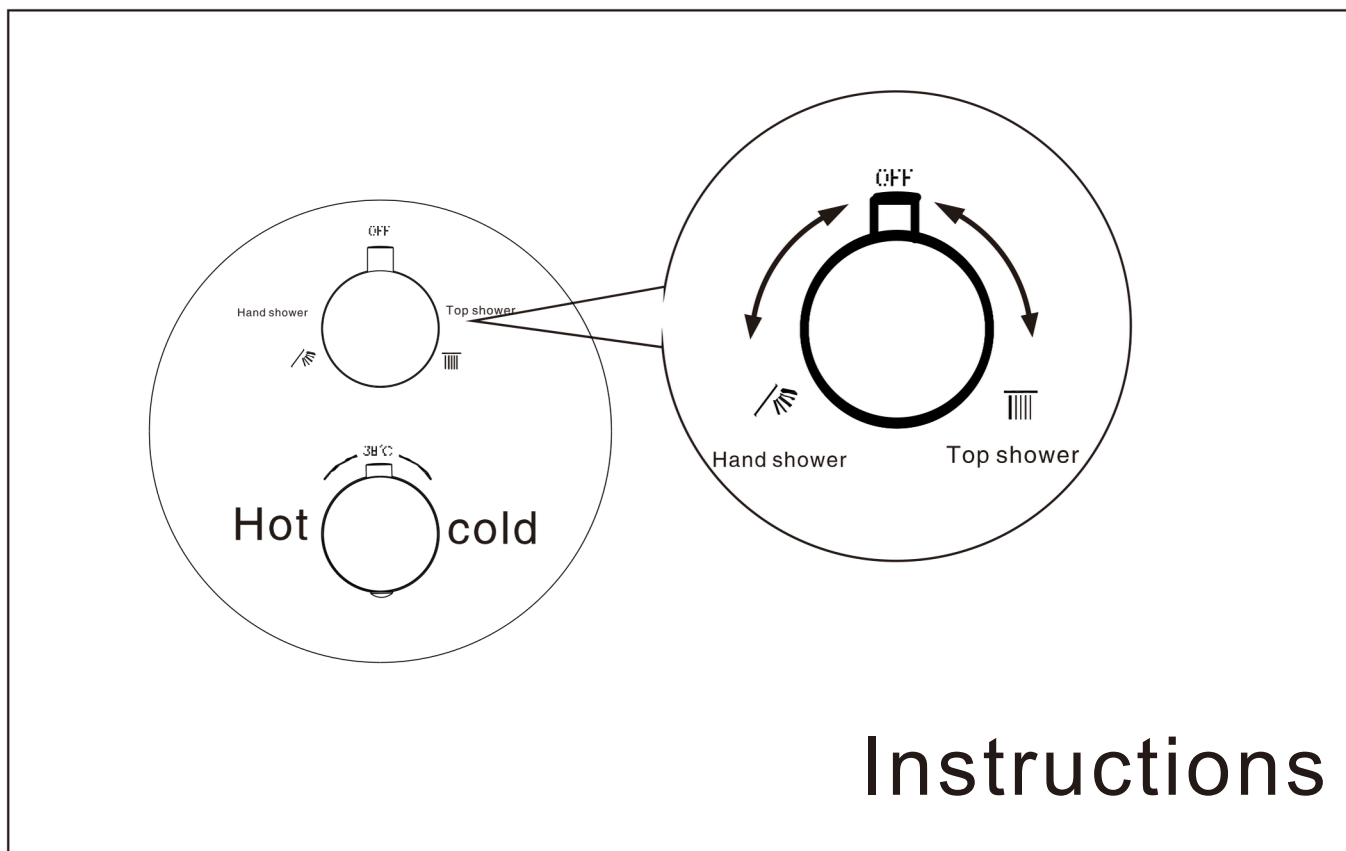

## Instructions

Pour que votre système de douche reste en parfait état, nettoyez-le régulièrement..

Pour garder votre système de douche en bon état :

1. Nettoyez avec de l'eau claire et un chiffon doux.

2.2. Si nécessaire, utilisez l'un de ces produits :

- Savon liquide doux
- Nettoyant incolore

3. Rincez bien pour enlever tout produit et séchez avec un chiffon doux.

- ◆ N'utilisez pas de nettoyeurs abrasifs ou de poudres à récurer.
- ◆ N'utilisez pas de nettoyeurs acides.



Rain Shower System

# Instruction Manual

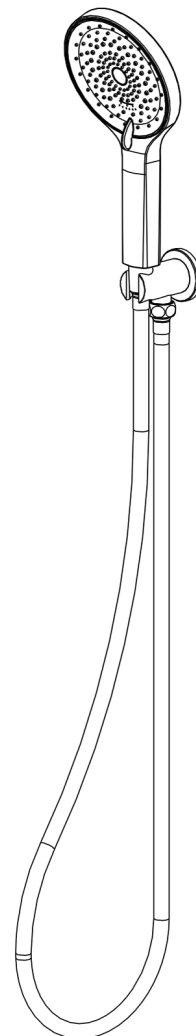
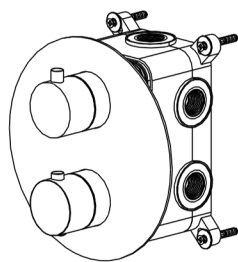
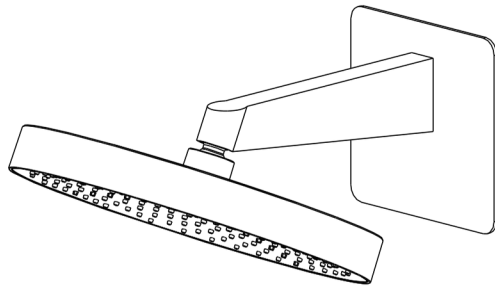

## Before Installation:



Thank you for choosing our Rain Shower System. Hope that you'll enjoy a comfortable smooth bathing experience with this product. Before installation, please read this installation manual carefully and keep it properly in case you need it . This manual is about the installation and use of this Rain Shower System.

### Technique Requirement

1. Proper Water pressure should be between 0.1Mpa-1.0Mpa, If water supply pressure exceeds 1.0 Mpa, a pressure reducing valve must be fitted.
2. Clean the impurity and sludge in the hose before assembling to avoid leaking and blockage
3. This shower system needs to be installed inside the wall. Please read this manual carefully to confirm the dimensions of products and keep the proper position on the wall.
4. The intake/outlet pipes need to be wrapped with Teflon tape. Use a Teflon tape to wrap a few turns in the clockwise direction on the thread of the pipes. (This is very important. The direction of the Teflon tape must be tangled clockwise. If not, it will leak.)
5. Turn off the water supply before installation

### Installation Tools To Be Needed

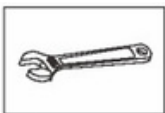

Adjustable wrench



Hexagon wrench  
(included)

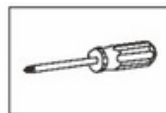

Phillips Screwdriver



Pipe Tape

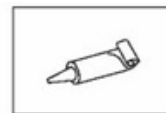

Glue

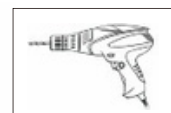

Electric drill

### Inventory Accessories

Please check carefully to make sure all the accessories are included in the package, if there is something missing, please contact the seller immediately.

# Product Dimensions



(Thickness of wall that we advise.)

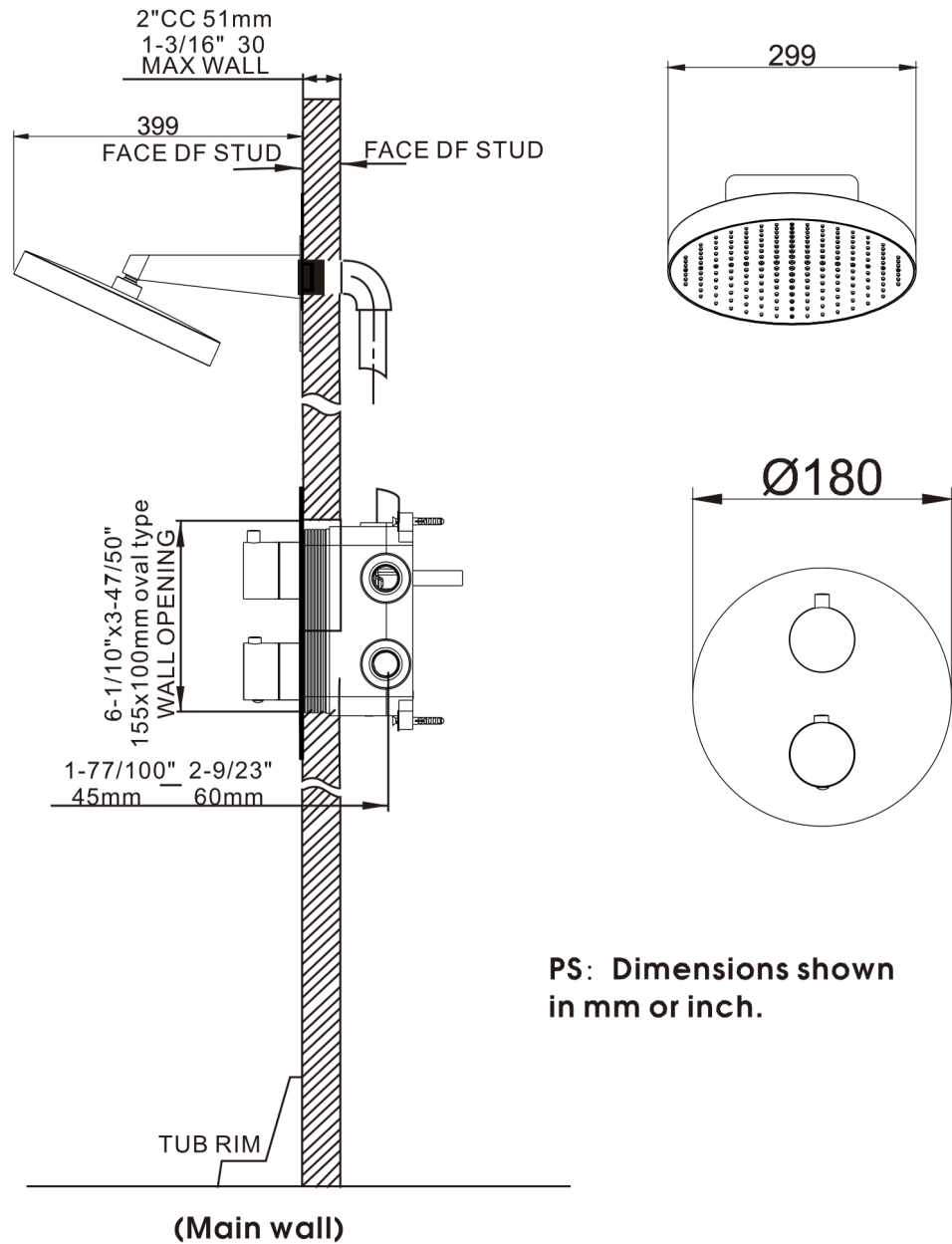

# Installation Of Rain Shower System



## ◆ Install The Shower Mixer Valve Control

Make sure the Shower Mixer Valve is connected to the correct Hot/Cold Water side

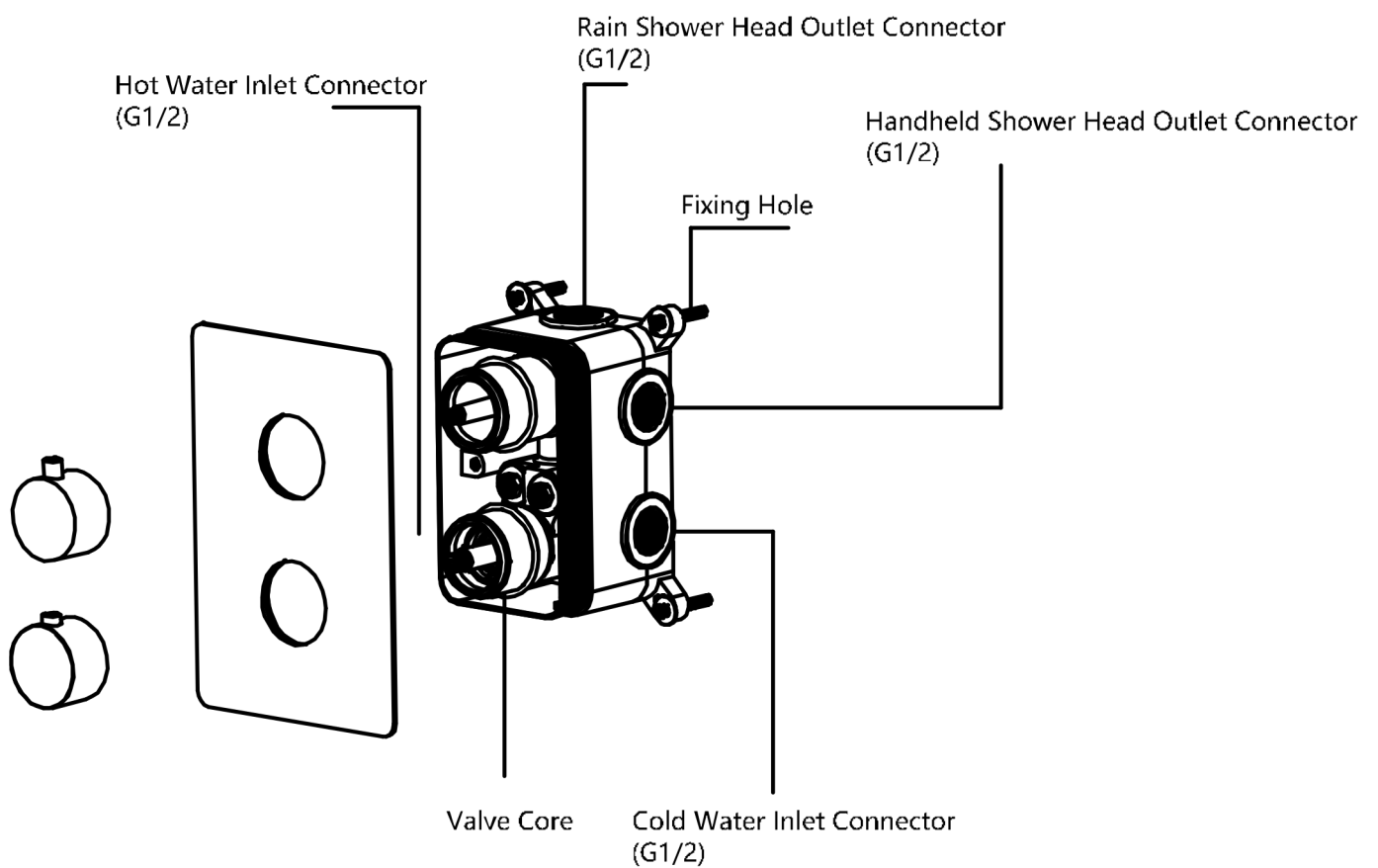

## ◆ Installation Steps

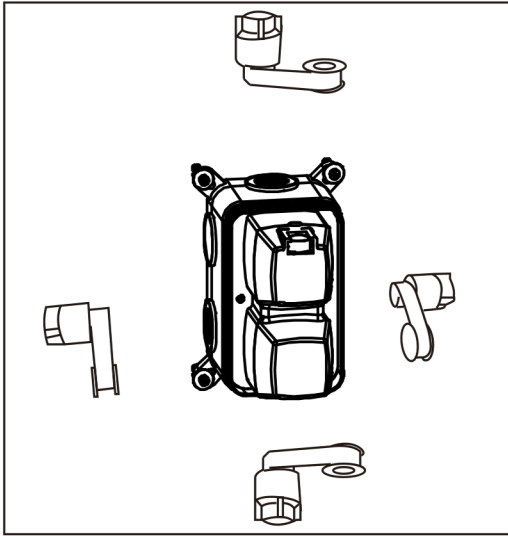

**Step 1:**  
The intake/outlet pipes need to be wrapped with Teflon tape. Use a Teflon tape to wrap a few turns in the clockwise direction on the thread of the pipes.

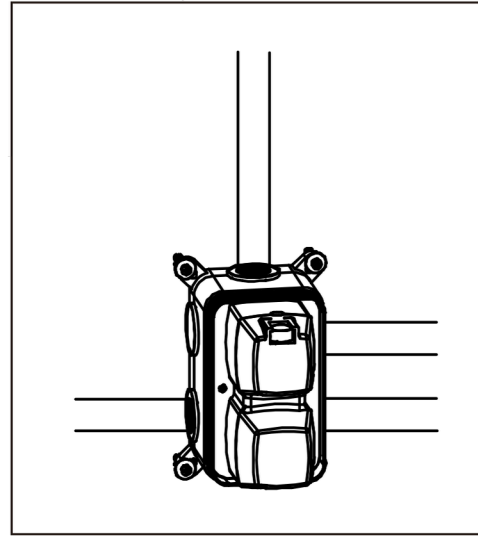

**Step 2:**  
Connect the water pipe with the embedded box.

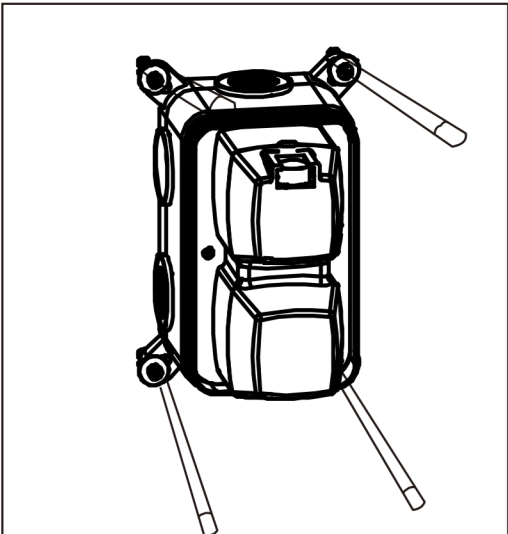

**Step 3:**  
Confirm the location of the embedded box and the pipes. Then mark them.

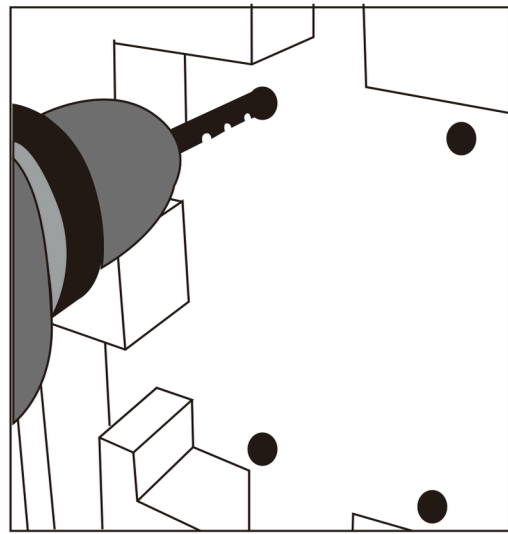

**Step 4:**  
After confirm the location, dig out the routes of the pipes. And remove the embedded box and drill the hole. Then use the electric drill to drill white screws ⑬ into the wall.

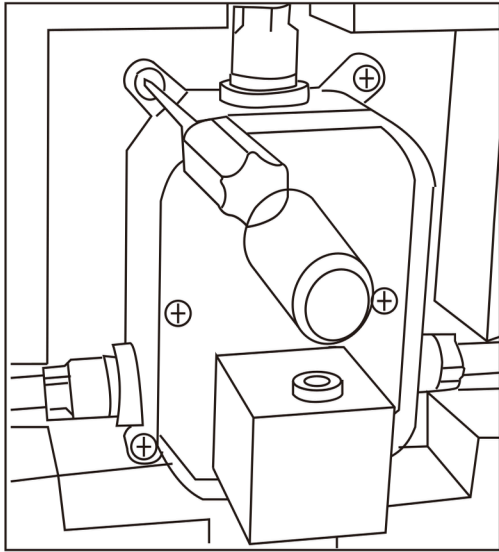

**Step 5:**  
Fix the embedded box on the wall  
with four screws.

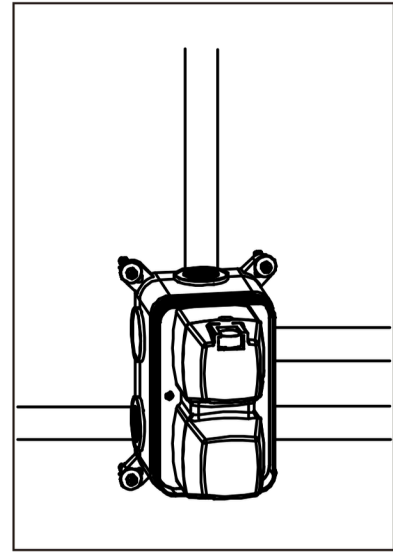

**Step 6:**  
Remove the embedded box cover from  
the valve control, then with the handle  
help, each inlet and outlet pipe shall be  
pressure tested to ensure no leakage.

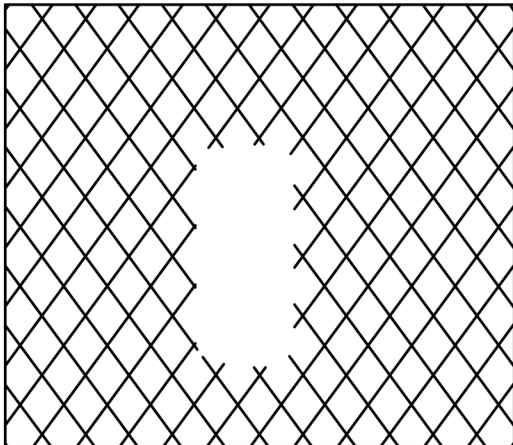

**Step 7:**  
The embedded box cover can protect  
the box from dust. Cover the embedded  
box and wait for the wall to be tiled.

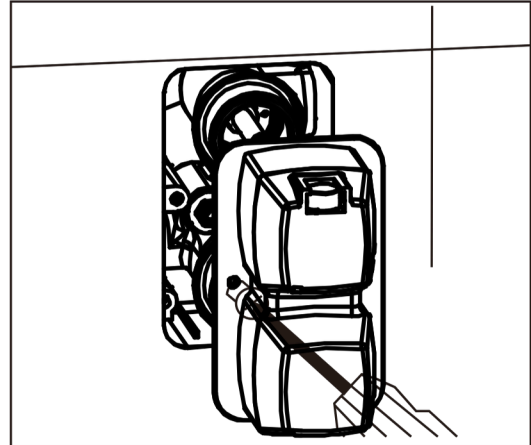

**Step 8:**  
After the wall tiled, remove  
the cover of the embedded box

◆ Install the panel

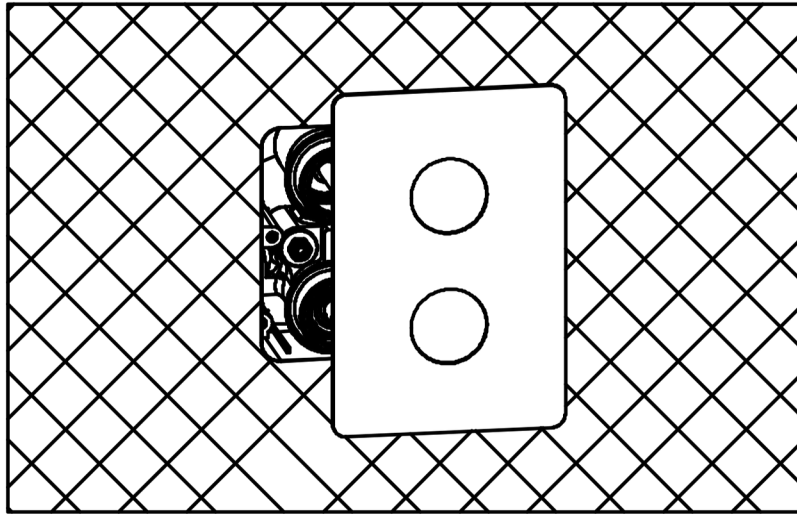

Step 1

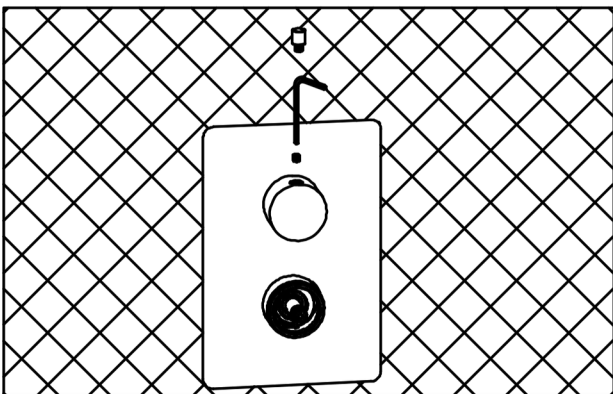

Step 2

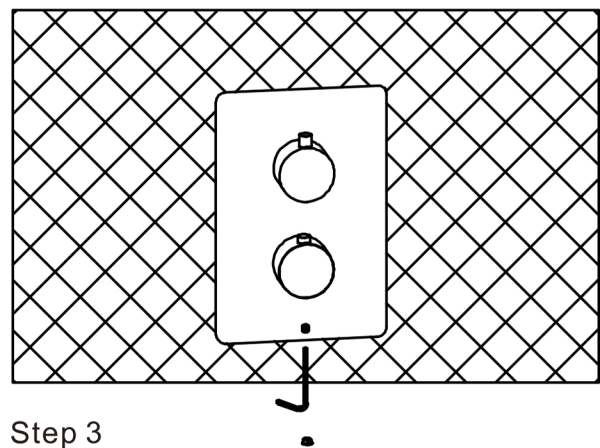

Step 3

Step1. Cover the panel.

Step2. Fix the Rain Mixer Valve Control with a hexagonal screw and a small cover.

Step3. Fix the Single Level Handle with a hexagonal screw and a small cover.

## ◆ Install The rain shower Head

For wall mounted showers

Step 1

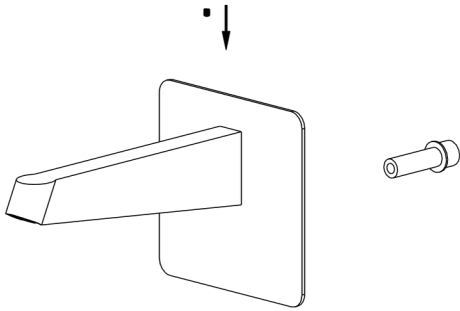

Step 1: Wind the waterproof belt around the water outlet joint and connect it to the water outlet pipe, and then connect the straight pipe with the water outlet joint the hexagon screw.

Step 2

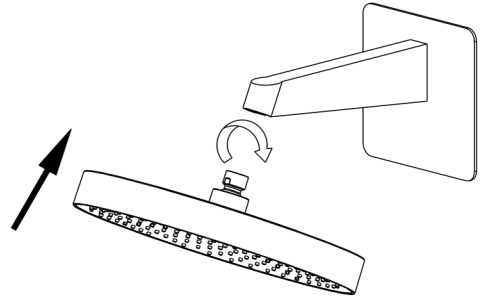

Step 2: Connect the top spray device to the straight pipe.

## Install the handheld shower head

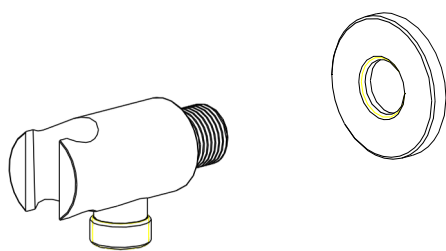

Step 1: After wrapping the waterproof belt around the hand shower fixing base, align the decorative cover and the fixing base, and then rotate to screw it into the.



Step 2. Connect the handheld shower and bracket holder with the hose.  
Make sure the rubber gaskets inside the hose



## Use And Care Instructions:



### ◆ Rain shower/ Handheld Shower Switch

Turn the switch to the “Top shower logo” and it will be the rain shower mode.

Turn the switch to the “Hand shower logo” and it will be handheld shower mode.

### ◆ Temperature Switch

The Logo “H” stands for Hot Water, “C” Stands for Cold Water, you can manually adjust the temperature by turning the handle to the H/C side

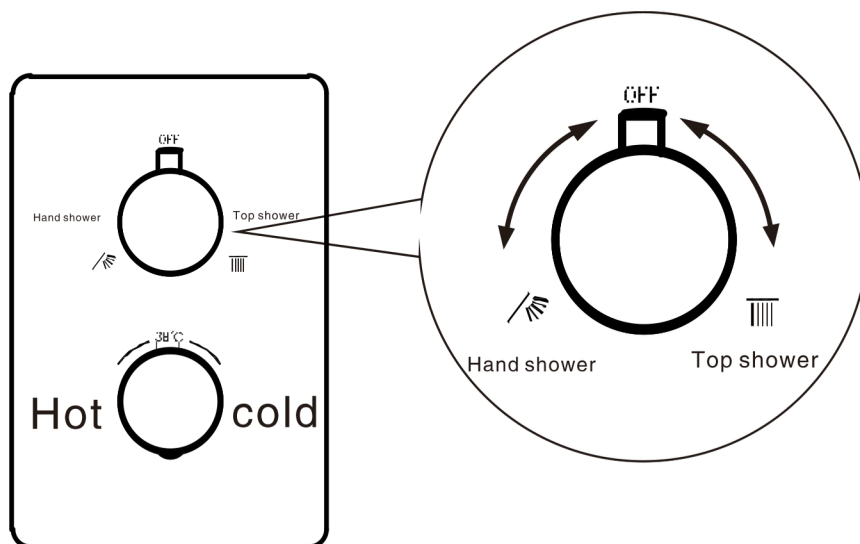

## Instructions

In order to keep your shower system look perfectly, we suggest cleaning the shower system regularly.

Please obey the following procedure when you clean the mixer.

1. Use clear water and the soft cloth to clean the dirt.

2. Use the any following cleanser to remove the dirt.

- Gentle liquid detergent.
- Colorless cleanser.

3. Please clean and remove all the cleanser after finish the cleaning, and dry with the soft cotton cloth.

◆ Avoid using polishing powder or cleaning powders including coarse particles for cleaning

◆ Avoid using acidic detergent for cleaning



Inbouwdouche

# Montage handleiding

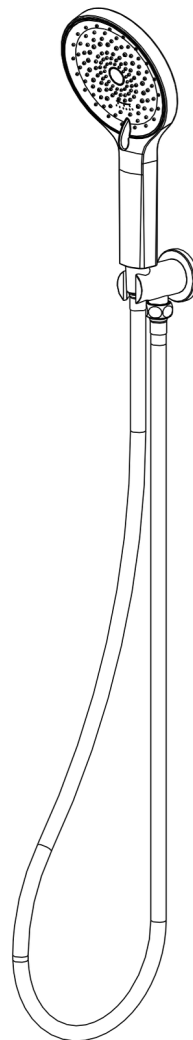
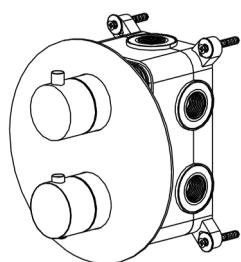
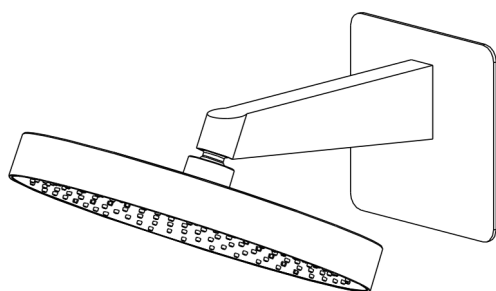

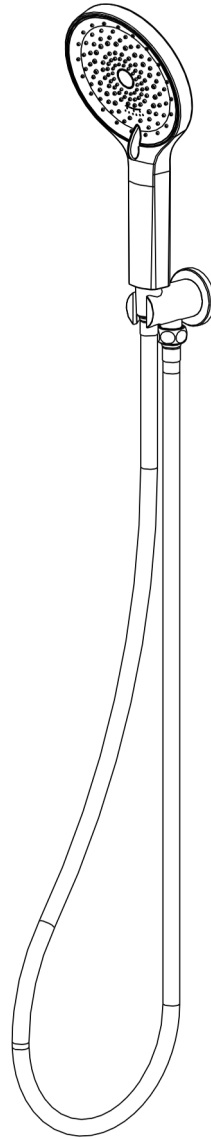
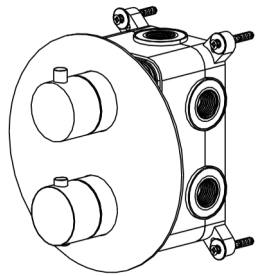
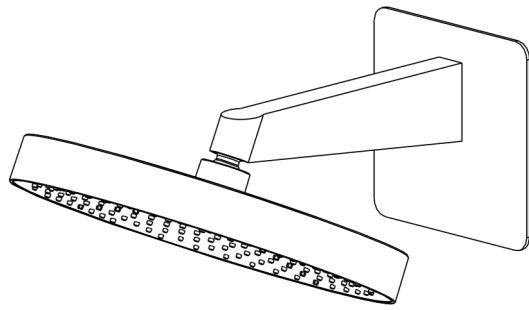



Bedankt dat u hebt gekozen voor onze inbouwdouche. We hopen dat u zult genieten van een comfortabele en soepele douche-ervaring met dit product. Lees vóór installatie deze handleiding zorgvuldig door en bewaar hem goed voor toekomstig gebruik.

## Technische vereisten

1. De juiste waterdruk ligt tussen 0,1 MPa en 1,0 MPa. Als de waterdruk hoger is dan 1,0 MPa, moet er een drukreducerend ventiel worden geplaatst.
2. Reinig eventuele onzuiverheden en slib uit de slang vóór montage om lekkage en verstopping te voorkomen.
3. Dit douchesysteem moet in de muur worden ingebouwd. Lees deze handleiding zorgvuldig door om de productafmetingen te bevestigen en om de juiste positie in de muur te bepalen.
4. De aanvoer- en afvoerleidingen moeten worden omwikkeld met teflontape. Wikkel de teflontape een paar slagen met de klok mee rond de schroefdraad van de leidingen (Dit is zeer belangrijk: de wikkeling moet met de klok mee draaien, anders kan er lekkage ontstaan.)
5. Zet de watertoevoer uit vóór de installatie.

## Benodigde gereedschappen

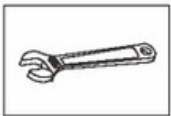

Verstelbare  
moersleutel



Inbussleutel  
(meegeleverd)

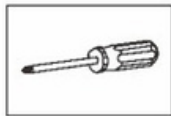

Kruiskopschroef-  
vendraaier



Teflontape



Lijm

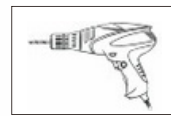

Elektrische boor

## Controle van installatie accessoires

Controleer zorgvuldig of de benodigde accessoires in de verpakking is meegeleverd. Neem bij ontbrekende onderdelen direct contact op met LOMAZOO.



## (Aanbevolen muurdikte)

(Afmetingen voor de uitsparing in de muur)

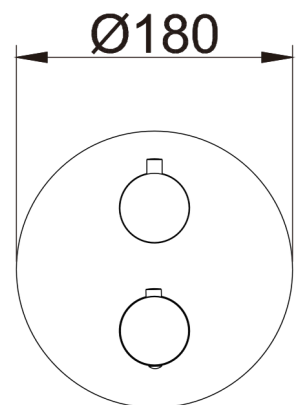
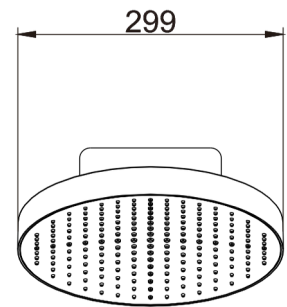
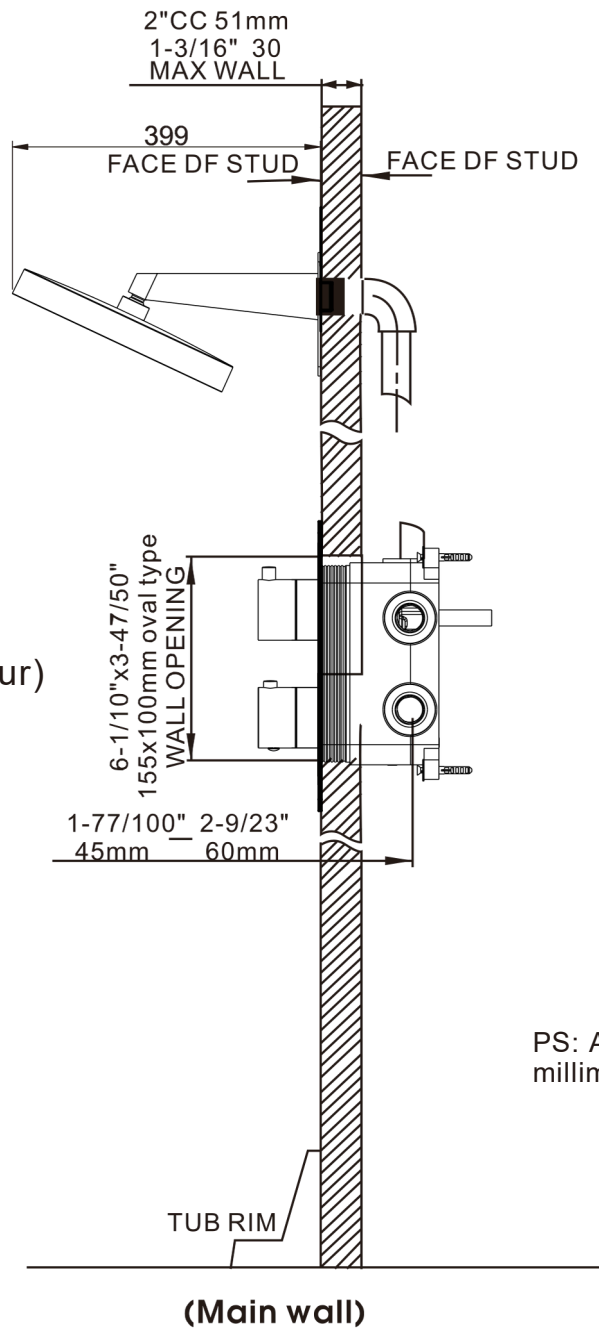

PS: Afmetingen zijn weergegeven in millimeters of inches.



## Monteren van de inbouwbox

Zorg ervoor dat de mengkraan correct wordt aangesloten op de juiste warm- en koudwaterzijde.

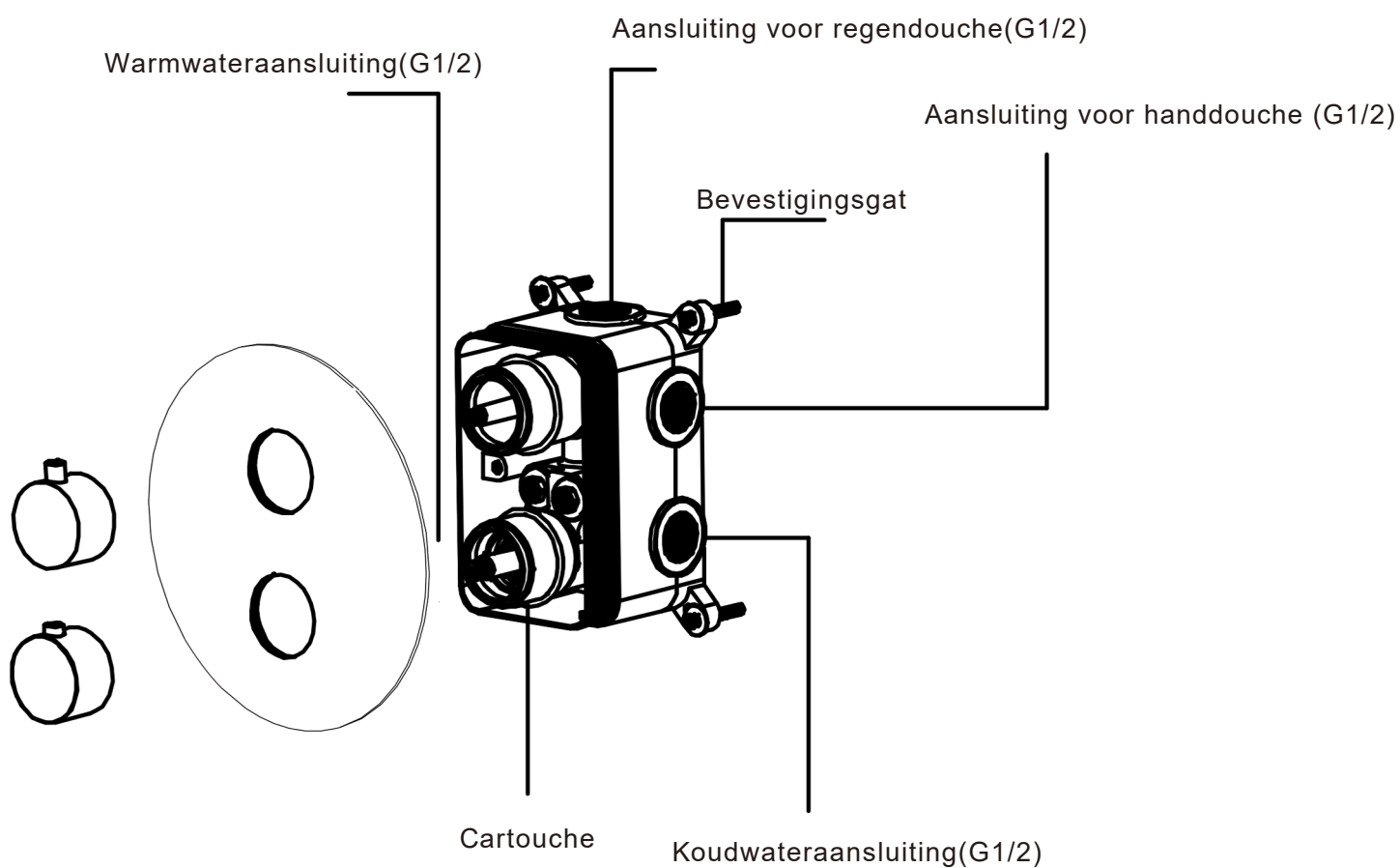

# Installatie stappen

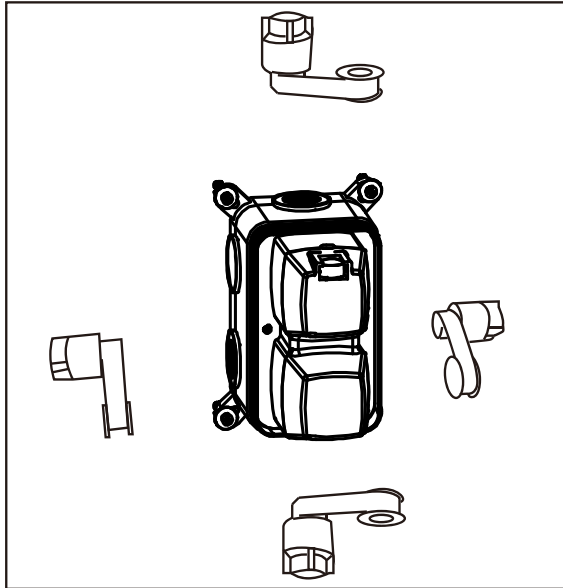

Stap 1:  
Omwikkel de aanvoer- en afvoerleidingen met teflontape. Wikkel de teflontape een paar slagen met de klok mee rond het schroefdraad van de leidingen.

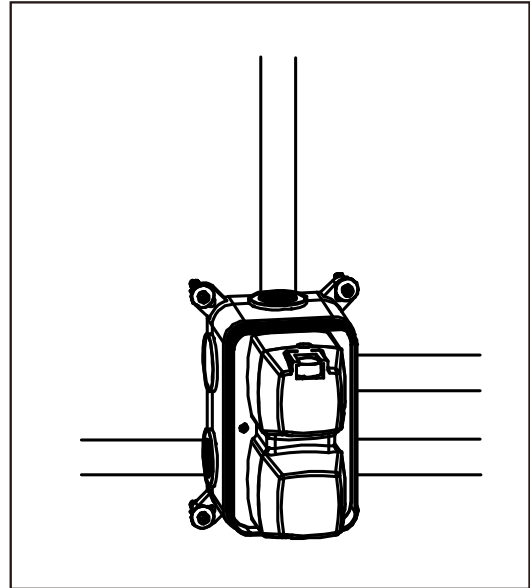

Stap 2:  
Sluit de waterleidingen aan op de inbouwbox.

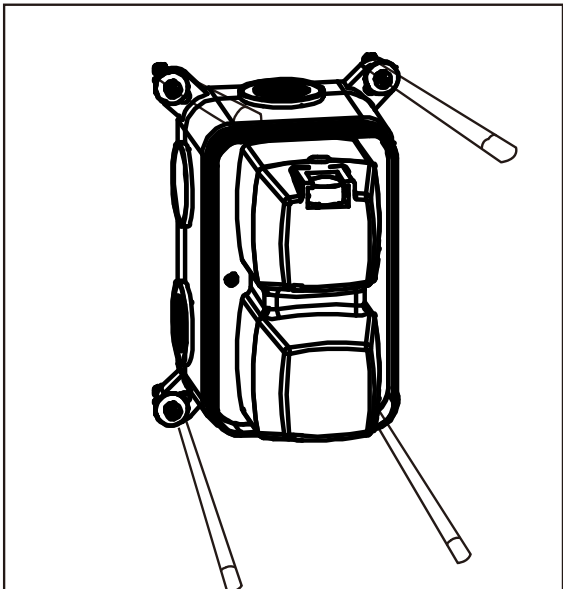

Stap 3:  
Bepaal de positie van de inbouwbox en de leidingen en markeer deze.

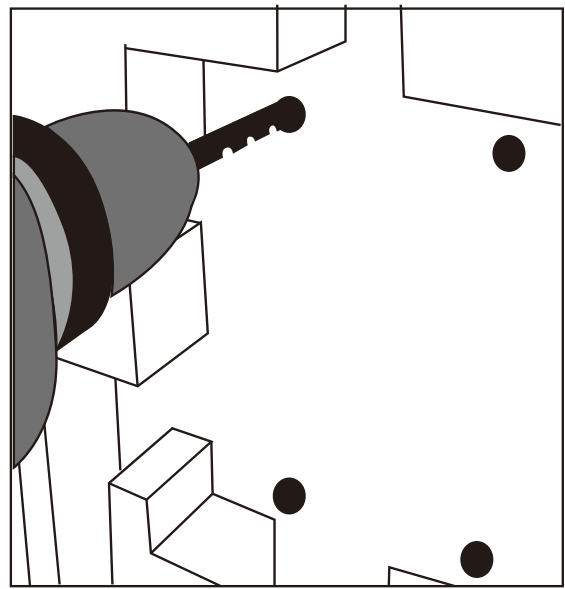

Stap 4:  
Nadat de positie is bepaald, hak de sleuven voor de leidingen uit. Verwijder de inbouwbox en boor de gaten. Gebruik daarna een elektrische boormachine om de witte schroeven (3) in de muur te plaatsen.

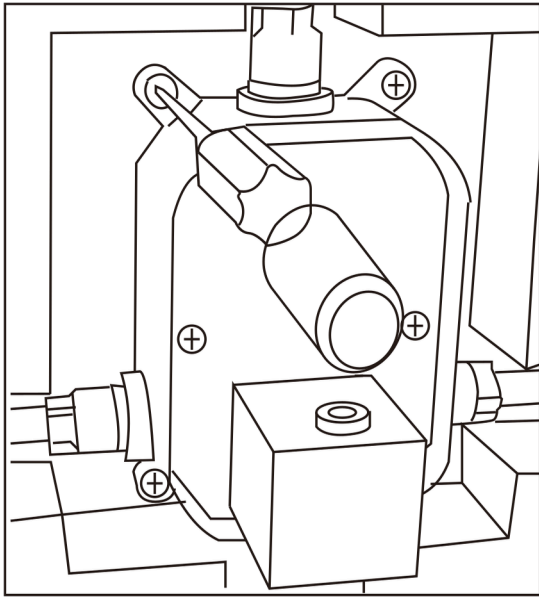

Stap 5:  
Bevestig de inbouwbox aan de muur met vier schroeven.

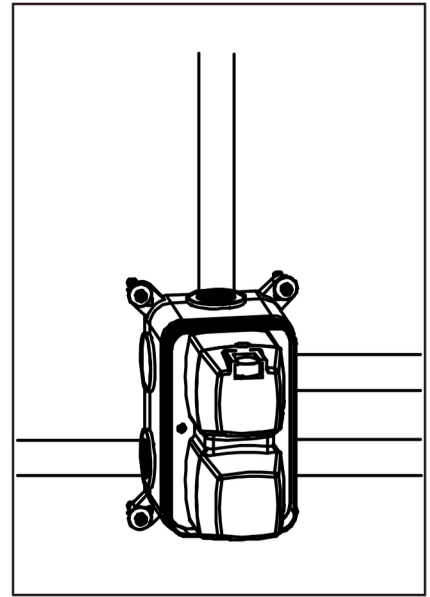

Stap 6:  
Verwijder de afdekking van de inbouwbox bij het mengventiel. Voer vervolgens, met behulp van de bedieningshendel, een druktest uit op elke aanvoer- en afvoerleiding om te controleren op lekkages.

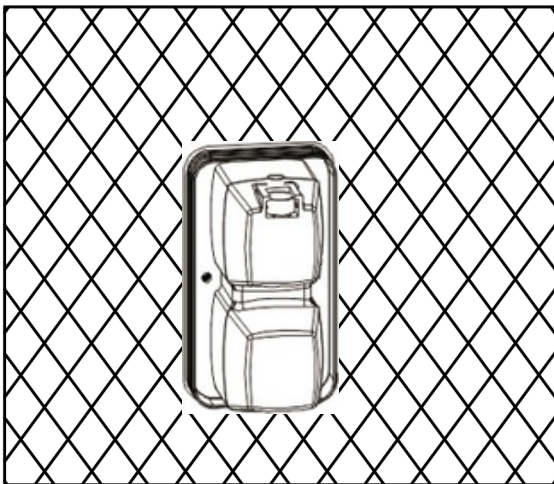

Stap 7:  
Dek de inbouwbox af tegen stof en vuil totdat de muur betegeld is.

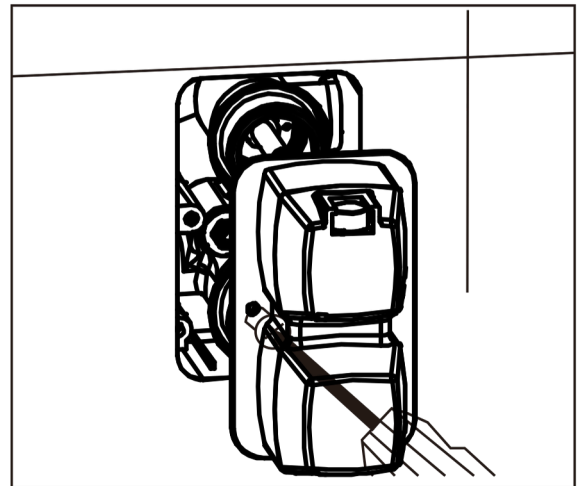

Stap 8:  
Verwijder, na het betegelen van de muur, de afdekking van de inbouwbox.

## Installatie van het paneel

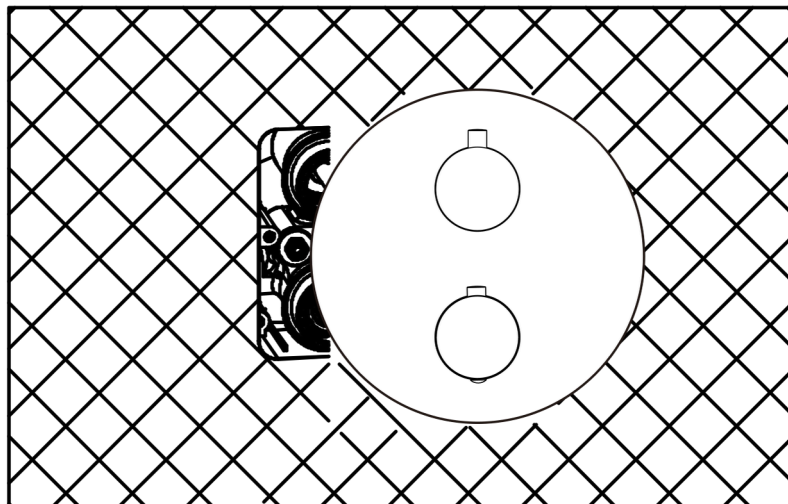

Step 1

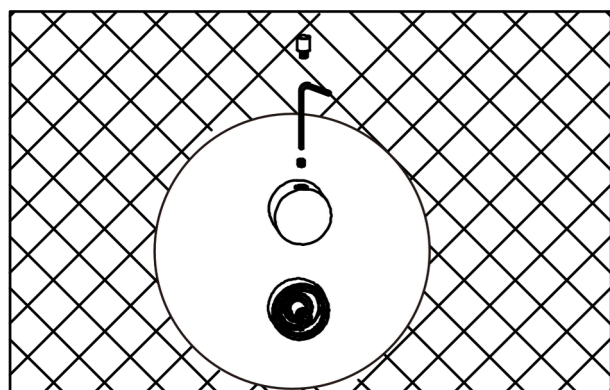

Step 2

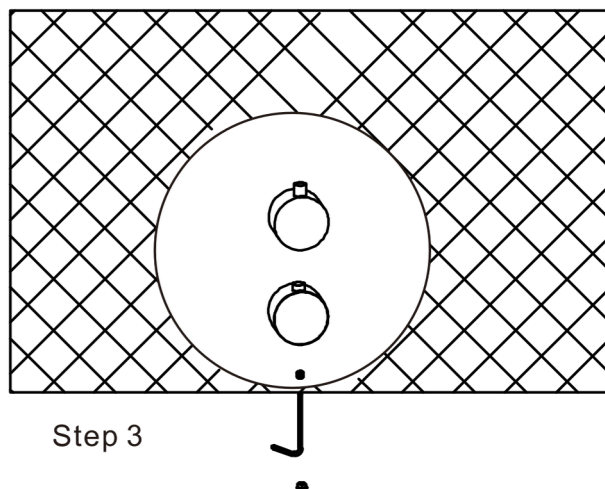

Step 3

Stap 1: Plaats het afdekpaneel over de inbouwbox.

Stap 2: Bevestig de bedieningsknop voor de regendouche met een inbusschroef en een kleine afdekkap.

Stap 3: Bevestig de eengreepshendel met een inbusschroef en een kleine afdekkap.

# Installatie van de regendouchekop

For wall mounted showers

Step 1

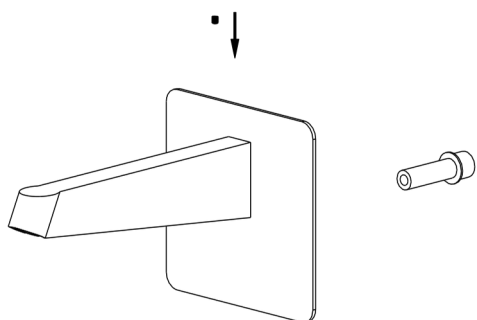

Stap 1:Wikkel teflontape om de schroefdraad van het aansluitpunt in de muur.Schroef daarna de rechte pijp vast op dit aansluitpunt met de inbussleutel.

Step 2

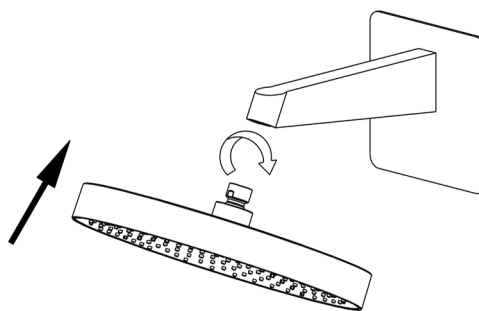

Stap 2:Bevestig de regendouchekop aan de douchearm.

## Installatie van de handdouche

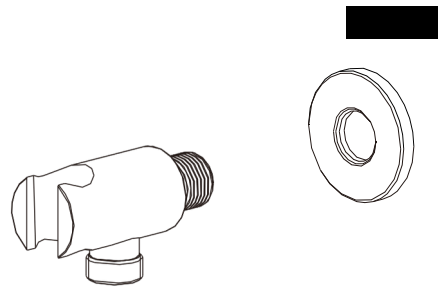

Stap 1: Doe teflontape om de schroefdraad van de houder voor de handdouche. Schuif de sierkap erover en draai de houder vast.

Stap 2: Bevestig de handdouche aan de houder met de doucheslang. Controleer of de rubberen ringetjes in de slang zitten.





## ◆ Regendouche/Handdouche Schakelaar

Zet de schakelaar op het "Top shower"-pictogram voor de regendouchestand.

Zet de schakelaar op het "Hand shower"-pictogram voor de handdouchestand.

## ◆ Temperatuurschakelaar

Het pictogram "H" staat voor heet water, "C" staat voor koud water. je kunt de temperatuur handmatig aanpassen door de hendel naar de H- of C-zijde te draaien.

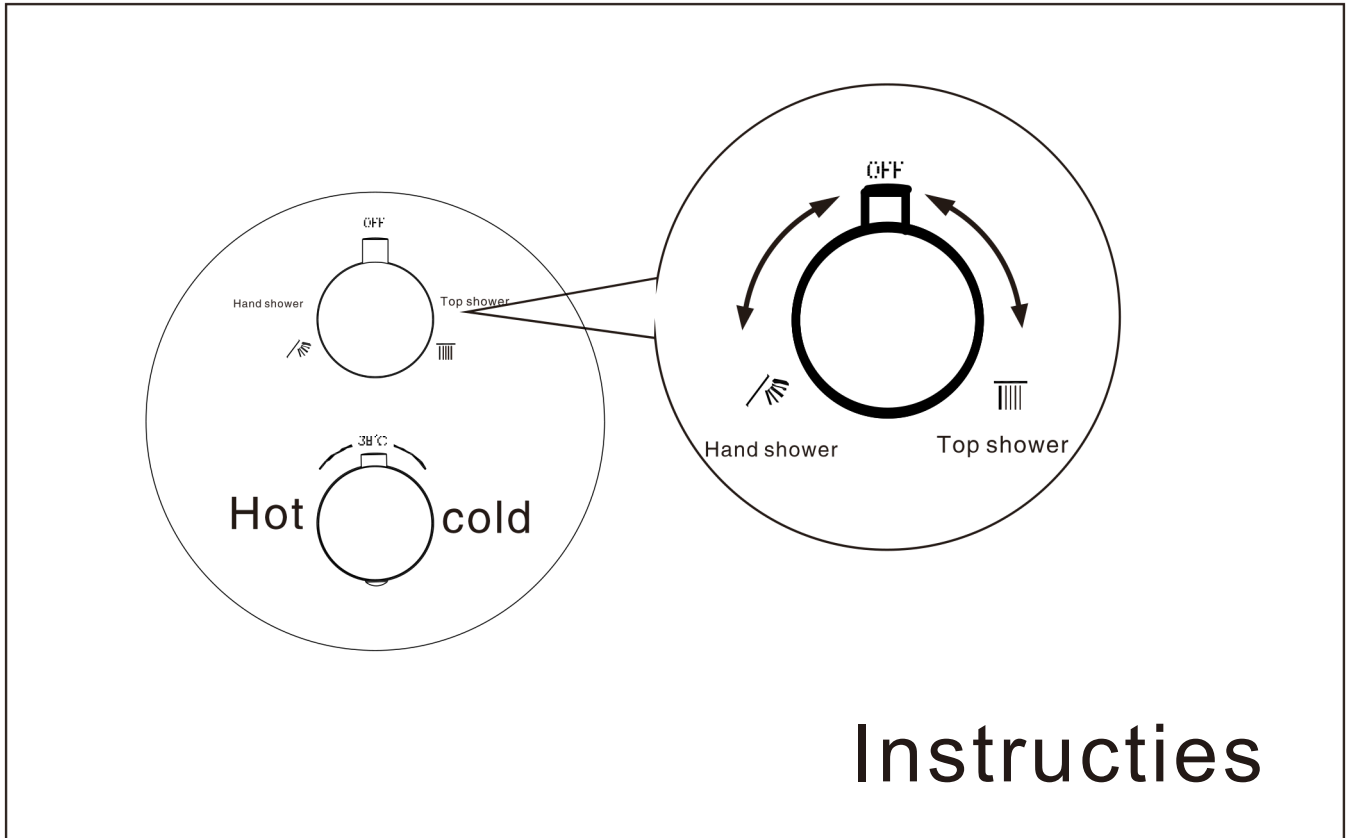

## Instructies

Om je douchesysteem er perfect uit te laten blijven zien, raden we aan om het systeem regelmatig schoon te maken.

Volg de onderstaande procedure bij het reinigen van de mengkraan:

1. Gebruik water en een zachte katoenen doek om vuil te verwijderen.

2. Gebruik een van de volgende reinigingsmiddelen om het vuil te verwijderen:

- Mild reinigingsmiddel
- Kleurloze reiniging

3. Zorg er na het schoonmaken voor dat alle resten reinigingsmiddel verwijderd is en droog af met een zachte doek.

- ◆ Vermijd het gebruik van poetsmiddel of schoonmaakpoeders met grovedeeltjes.
- ◆ Vermijd het gebruik van zure en harde reinigingsmiddelen.